

### Modular Power Architecture Up to 50W Power for 24V/28V Avionics/Military Applications

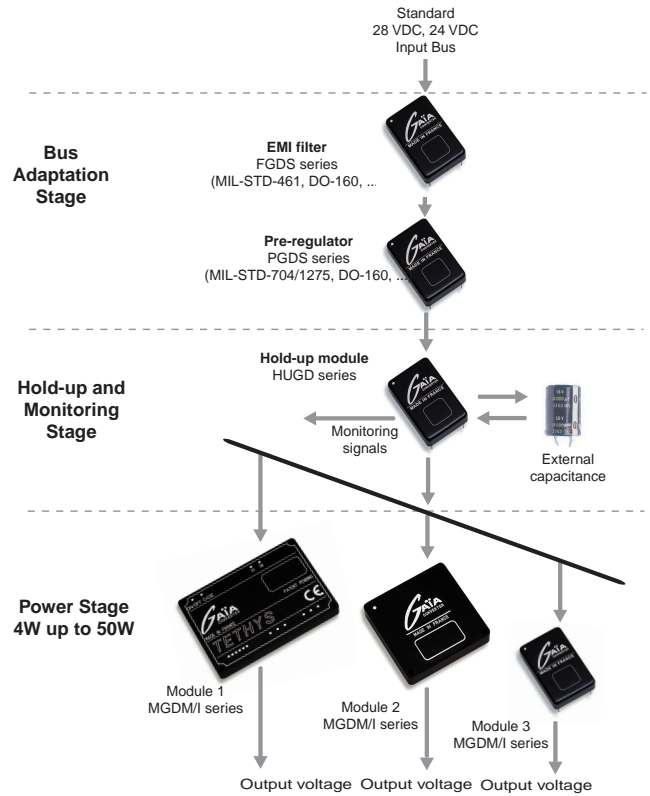

## 1- General

### 1-1 Introduction

This application note describes how to use GAIA Converter DC/DC converters and front-end modules PGDS-50 and HUGD-50 to build a complete power supply that meets avionics/military standards. This modular power architecture is dedicated for 24V and 28V bus powered electronics up to 50W power.

### 1-2 Modular Power Architecture

The use of modular power architecture by using «ready-to-use» building block modules offer to designers many benefits.

Development time is drastically shorter over a traditional custom approach.

The use of standard «mass produced» building block modules is cost-effective over a custom design. It is a versatile and multi-applications oriented, qualification is facilitated by using already qualified building blocks.

### 1-3 The 24Vdc/28Vdc Input Bus in Avionics/Military Applications

The 24Vdc and 28Vdc input busses are one of the most widely used input voltages for low power and critical systems for :

- airborne applications
- groundborne applications

A lot of constraints are existing around those input busses including transients, spikes, cranking, power transfer, recovery after power fail, electromagnetic interferences, .....

GAIA Converter has developed a standard easy-to-use and fully qualified modular power architecture to cover all these requirements.

The following sections will underline the different requirements to fulfill in the main area such as :

- Input voltage requirements,
- Electromagnetic interference requirements,
- Output noise requirements,
- Environmental conditions requirements,
- Thermal management.

## 2- Input Bus Voltage Requirements

### 2-1 General

Airborne or groundborne electronic systems powered directly from 24Vdc or 28Vdc batteries or generator, shall sustain wide input excursions, including transients, spikes, cranking and shut down.

Those input variations are described in different standards, in which the most frequently used are as follows :

- For Airborne Applications :
  - The US MIL-STD-704 standard : "Aircraft Electric Power Characteristics".
  - The International DO-160 standard : "Environmental Conditions and Test Procedures for Airborne Equipment".
  - The European En 2282 standard : "Characteristics of Aircraft Electrical Supply".
  - The British BSI 3G 100 : "Characteristics of Aircraft Electrical Power Supplies".
  - The Airbus ADB 100 chap. 8 standard : "Equipement Requirements for Suppliers, electric"
- For Groundborne Applications :
  - The US MIL-STD-1275 standard : "Characteristics of 28 VDC Electrical Systems in Military Vehicles".
  - The British DEF STAN 61-5 Part 6 Electrical Power Supply 28 VDC Electrical Systems in Military Vehicles.

### 2-2 Modes of Operations

The different standards describe different modes of operations :

- Permanent input voltage range in normal, abnormal and emergency conditions,
- Brown-out and transient levels in normal and abnormal conditions,
- Spike levels,
- Start up voltage and cranking levels,
- Shut down (or transparency) levels.

The different permanent input ranges are achieved by using standard GAIA Converter DC/DC modules without any additional devices.

The brown-out, engine start or cranking and transient levels are more aggressive and are achieved by using GAIA Converter front-end module designated "PGDS-50". The PGDS-50 module is a transient protection module (see datasheet PGDS-50 for further details).

The spike protections are achieved with EMI filter module FGDS-2A-50V (see datasheet FGDS-2A-50V for further details)

The shut down mode of operation is satisfied with an external hold up device (capacitance and/or a GAIA Converter hold up module «HUGD-50»). The HUGD-50 module used in conjunction with an external capacitance is a hold-up charger and controller. (see HUGD-50 datasheet for further details)

GAIA Converter proposes a typical architecture to cover all these requirements (see figure hereby).

This architecture includes :

- Front-end modules :
  - EMI filter module FGDS-2A-50V
  - Pre-regulator module PGDS-50
  - Hold-Up module HUGD-50
- a complete range of DC/DC modules

Each module is satisfying the following mode of operations :

Input Bus Status	Active Module	Operations
EMI Filter	FGDS-2A-50V	EMI filtering and spike suppressor
Transients	PGDS-50	Transient suppressor
Normal	DC/DC	Generation of DC voltages
Low line	PGDS-50	Boost voltage for proper DC operation
Hold up	HUGD-50	used in conjunction with capacitance to provide energy

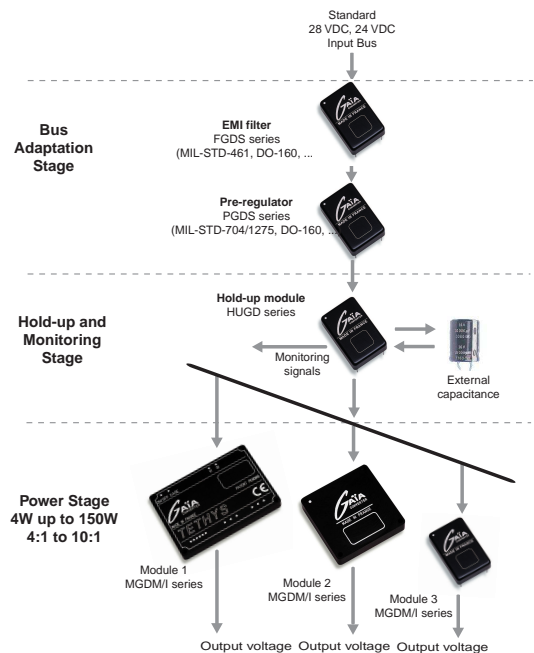

## 2- Input Bus Voltage Requirements (continued)

The following tables describe for some airborne and groundborne applications the GAIA Converter modular power architecture compliance. Please consult Avionics/Military COTS application note for further details.

### 2-2 Airborne Applications

International Standards	<----- Steady State ----->			<----- Transient ----->			<- Spike ->	GAIA Converter DC/DC and Front-end Module Compliance
	Normal	Abnormal	Emergency	Low Normal	High Abnormal	Low Abnormal		
	MIL-STD-704A (cat A)	25 - 28,5V	23,5 - 30V	17 - 24V	10V/50ms	80V/50ms		
MIL-STD-704F	22 - 29V	20 - 31,5V	16 - 29V	18V/15ms	50V/50ms	0V/up to 7s	/	GAIA DC/DC range : 16-40V or 16-80V GAIA DC/DC 16-40V with 50V transient or 16-80V HUGD series with capacitor*
DO-160D (cat B) spike cat. A	22 - 30,3V	20,5 - 32,2V	18V	12V/30ms	60V/100ms	0V/up to 7s	+/-600V/10µs	GAIA DC/DC range : 9-36V, 16-40V or 16-80V PGDS series : 10V/15s or GAIA DC/DC range 9-36V PGDS/LGDS series HUGD series with capacitor* FGDS series
DO-160D (cat Z) spike cat. A	22 - 30,3V	20,5 - 32,2V	18V	12V/30ms	80V/100ms	0V/up to 7s	+/-600V/10µs	GAIA DC/DC range : 9-36V, 16-40V or 16-80V PGDS series : 10V/15s or GAIA DC/DC range 9-36V PGDS/LGDS series HUGD series with capacitor* FGDS series
DO-160E (cat Z) spike cat. A	22 - 30,3V	20,5 - 32,2V	18V	12V/30ms	80V/100ms	0V/up to 7s	+/-600V/10µs	GAIA DC/DC range : 9-36V, 16-40V or 16-80V PGDS series : 10V/15s or GAIA DC/DC range 9-36V PGDS/LGDS series HUGD series with capacitor* FGDS series
AIR2021E	24 - 29V	20,5 - 32,2V	17V	12V/30ms	60V/50ms	0V/up to 5s	+/-600V/10µs	GAIA DC/DC range : 9-36V, 16-40V or 16-80V PGDS series : 10V/15s or GAIA DC/DC range 9-36V PGDS/LGDS series HUGD series with capacitor* FGDS series

Note \* : the duration of low abnormal condition 0V has to be specified by the user, the maximum duration will be limited according to the power needed and the HUGD maximum capacitance, refer to HUGD datasheet

### 2-2 Groundborne Applications

International Standards	Steady State	Start Engine	Cranking	<----- Surge ----->		Spike	GAIA Converter DC/DC and Front-end Module Compliance
				Low	High		
MIL-STD-1275C/D (generator + battery)	25 - 30V	6V/1s	16V/30s	20V/500ms	40V/50ms	+/-40V/1ms/15mJ +/-250V/70µs/15mJ	GAIA DC/DC range : 9-45V or 9-36V with 40V/100ms PGDS series : 6V/1s FGDS series
MIL-STD-1275C/D (battery only)	20 - 27V	6V/1s	16V/30s	/	/	+/-40V/1ms/15mJ +/-250V/70µs/15mJ	GAIA DC/DC range : 9-45V or 9-36V with 40V/100ms PGDS series : 6V/1s FGDS series
MIL-STD-1275C/D (generator only)	23 - 33V	/	/	15V	100V/50ms	+/-100V/1ms/15mJ +/-250V/50µs/15mJ	GAIA DC/DC range : 9-45V or 9-36V PGDS/LGDS series FGDS series
DEF STAN 61-5 issue 5 (generator + battery)	25 - 30V	6V/1s	>15V	20V/500ms	40V/50ms	+130V/-100V/<10µs +90V/-60V/10µs +70V/-40V/5ms	GAIA DC/DC range : 9-45V or 9-36V with 40V/100ms PGDS series : 6V/1s FGDS series PGDS/LGDS series
DEF STAN 61-5 issue 5 (battery only)	22 - 27V	1V/1s	>10V	/	/	+130V/-100V/<10µs +90V/-60V/10µs +70V/-40V/5ms	GAIA DC/DC range : 9-45V or 9-36V with 40V/100ms External capacitance FGDS series FGDS series PGDS/LGDS series
DEF STAN 61-5 issue 5 (generator only)	15 - 40V	/	/	15V/500ms	80V/80ms	+280V/-220V/<10µs +130V/-70V/10µs +110V/-50V/5ms	GAIA DC/DC range : 9-45V or 9-36V PGDS/LGDS series FGDS series PGDS/LGDS series

## 2- Input Bus Voltage Requirements (continued)

### 2-4 Input Bus Shut-Down Requirements

When input bus voltage shut-down the use of a storage energy device is necessary.

There are 2 ways to comply :

- the use of a stand-alone bulk capacitor
- the use of GAIA Converter HUGD-50 module together with a capacitor.

Both solutions are described thereafter.

#### 2-4-1 Bulk Capacitor Solution

During bus power drop-out, avionics and military systems require a maintain of operation for saving data and controlling the shut-down. The duration of this shut-down operation is defined in different standards explained in previous table in section 2-2 and can go up to 7 seconds.

To maintain operation during this power drop-out, the traditional approach is the use of a bulk capacitor connected at the input of the converters to power them when power drops-out. The capacitor needed depends on the system specifications, the load and the efficiency of the DC/DC converters and the amount of capacitor for a given hold-up time is determined by the following formula :

$$C1 = \frac{(2 \times P \times Dt)}{\{h \times (V1^2 - V2^2)\}}$$

where :

- C : is the required capacitor (in farads)
- P : is the power at the load (output of converter) (in watts)
- h : is the efficiency of the converter at rated load
- Dt : is the required hold up time (in seconds)
- V1 : is the initial charged capacitor voltage (in volts)
- V2 : is the low line voltage of DC/DC converter

For a typical hold-up time of 50 ms with 50W power (at the input of the DC/DC converter with 80% efficiency) plugged on a MIL-STD-704D 28V bus that can range down to 22V and considering the minimum permanent input voltage of GAIA Converter module at 16V, the required capacitance is a huge 27.400  $\mu$ F/40V rated.

#### 2-4-2 Hold Up Module Solution

To reduce drastically the size of this capacitor, GAIA Converter proposes a hold up module that will charge the capacitor at a much higher voltage (typically 38V).

Moreover this module allows a selection of the minimum threshold voltage at which the capacitance will begin to power the converters. In this case the amount of capacitance for a given hold up time is determined by the following formula :

$$C2 = \frac{2 \times P \times (Dt + 0.01)}{\{h \times (38^2 - V2^2)\}}$$

where :

- C : is the required capacitor (in farads)
- P : is the power to the load (output of converter) (in watts)
- h : is the efficiency of the converter at rated load
- Dt : is the required hold up time (in seconds)
- V2 : is the low line voltage of DC/DC converter (in volts).

For a typical hold-up time of 50 ms with 50W power (at the input of the DC/DC converter with 80% efficiency) plugged on a MIL-STD-704D 28V bus and using the hold up module the capacitance required will decrease down to 6.300  $\mu$ F/40V rated.

Moreover this module provides monitoring signals of capacitor charge, discharge, power fail, and is able to drive complex avionics systems micro- shut-down, cold and hot start, .....

## 2- Input Bus Voltage Requirements (continued)

### 2-5 Typical Schematics

To take into account the different constraints described in table of section 2-2, GAIA Converter recommends the following schematics integrating either the pre-regulator module PGDS-50 for transient and low line operation together with the hold-up module HUGD-50 and a bulk capacitance for drop-out operation.

A typical schematic will be built with the following settings :

- Hold-up module : HUGD-50
  - Setting of the «power fail threshold» Vth (adjustable between about 9V and 16V) which will determine the voltage limit under which the system will work in hold-up mode using only the capacitance energy. This setting is realized with a resistance Rth connected between the pin Vth and the G0 pin :
  - Rth : Vth unconnected will give a threshold of about 16V,
  - Rth : Vth connected to ground will give a threshold of about 9 V.

If the PGDS-50 is used in conjunction with HUGD-50 module the pin Vth has to remain unconnected.

- Setting of the «charging current level» between 100 mA up to 2A will determine the charging time. A resistance Rcl connected between the pin Vcl and the pin G0 of 1K will give a charging time of 150µs/µF; a 2K will give about 475µs/µF.

Additional details on these settings are given in the HUGD-50 datasheet together with detailed operations.

- pre-regulator module : PGDS-50
 

No settings are necessary, the PGDS-50 modules need just a voltage reference Vimes connected at a filtered input of the power bus.

Additional details on PGDS-50 is given in the PGDS technical datasheet.

- For bulk capacitance  
The calculation is given by the following formula :

$$C = \frac{2 \times P \times (Dt+0.01)}{\{\eta \times (38^2 - V2^2)\}}$$

where :

- C : is the required capacitor (in farads)
- P : is the power to the load (output of converter) (in watts)
- h : is the efficiency of the converter
- Dt : is the required hold up time (in seconds)
- V2 : is the low line voltage of DC/DC converter

- Transition capacitor
 

To help transitioning the system in the different operating mode, GAIA Converter recommends the use of a transition capacitor. A 100µF electrolytic capacitor is recommended for 50W load and can be reduced for lower loads. Details are given in HUGD datasheet.

- EMI filter : FGDS-2A-50V
 

To sustain EMI requirements a front filter is recommended. The following section 3 describes this filter.

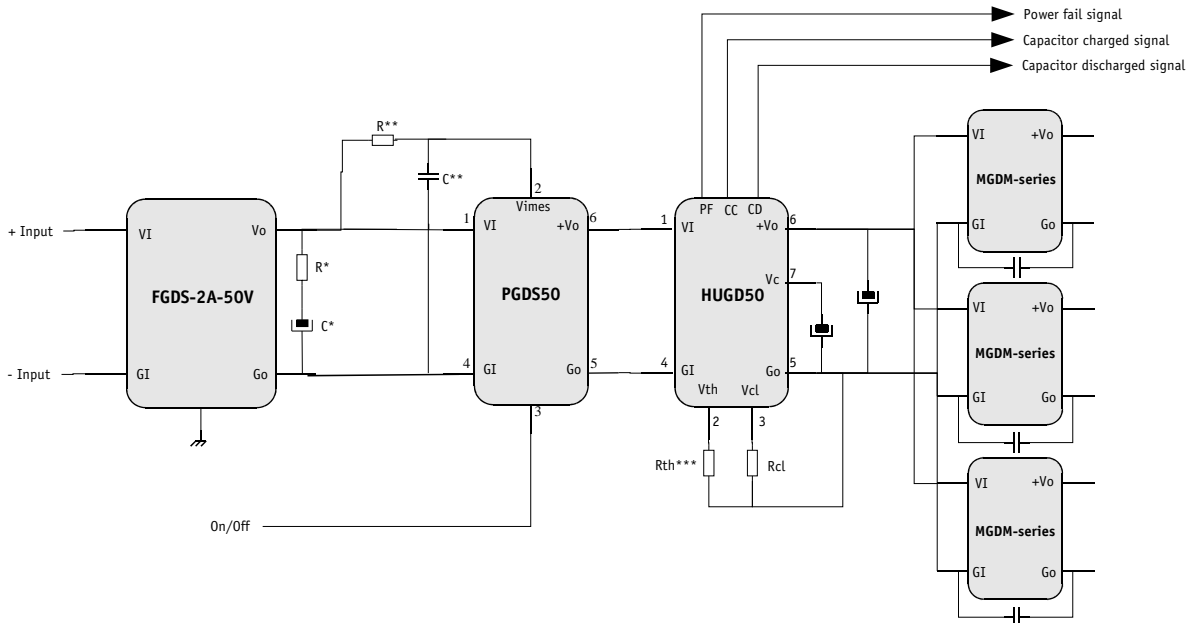

Note \* : GAIA Converter recommends the use of a R\*C\* cell for better EMI performances together with FGDS-2A-50V (see section 3 or FGDS-2A-50V datasheet)

Note \*\* : Due to possible oscillations caused by surges or fast transients at the input voltage level, it is recommended to implement a R\*\*C\*\* filter on the VIMES signal; several implementations as shown in the above figure can be tested to optimize the design. Typical values for the resistor R is 470 Ohm and for the capacitance C is 1µF.

Note \*\*\*: When used in conjunction with PGDS-50 series, the resistance Rth of HUGD module has to be left unconnected.

### 3- Electromagnetic Interference Compatibility Requirement

Airborne or groundborne electronic systems shall sustain severe level of electromagnetic interference requirements. Those interference levels are defined in different standards whereas the most popular are :

- The US MIL-STD-461C standard : “Electromagnetic Interference Characteristics, Requirements for Equipment”.
- The US MIL-STD-461D/E/F standards : «Requirements for the control of electromagnetic Interference Emissions and Susceptibility».

- The DO-160C/D/E/F/G standard : “Environmental Conditions and Test Procedures for Airborne Equipment”.

The requirements are divided into :

- Conducted emission (CE),
- Conducted susceptibility (CS),
- Radiated emission (RE),
- Radiated susceptibility (RS).

The following tables resume GAIA Converter products compliance with the requirements

Specifications	MIL-STD-461C	MIL-STD-461D/E/F	DO-160C/D/E/F/G	GAIA Converter Module Compliance
Conducted emission (CE) :				
Low frequency	CE 01	CE 101	Section 21	module compliant stand alone (see product datasheet)
High frequency	CE 03	CE 102	Section 21	module compliant with additional filter
Conducted susceptibility (CS) :				
Low frequency	CS 01	CS 101	Section 20	module compliant with additional filter
High frequency	CS 02	CS 114	Section 20	module compliant with additional filter
Radiated emission (RE) :				
Magnetic field	RE 01	RE 101	Section 21	module compliant stand alone (see product datasheet)
Electrical field	RE 02	RE 102	Section 21	module compliant stand alone (see product datasheet)
Radiated susceptibility (RS) :				
Magnetic field	RS 01	RS 101	Section 20	module compliant stand alone (see product datasheet)
Electrical field	RS 03	RS 103	Section 20	module compliant stand alone (see product datasheet)

#### 3-1 Compliance with DO-160C/D/E/F/G and MIL-STD-461C/D/E/F Standards

To meet the international DO-160C/D/E/F/G and US military standards MIL-STD-461C, and MIL-STD-461D/E/F requirements and in particular CE03 and CE102 requirements, Gaia Converter can propose a ready-to-use EMI filter module : FGDS-2A-50V. For better EMI performance and stability purpose, GAIA Converter recommends to use a R\*C\* cell together with a common mode noise capacitance Cc (10nF typical) connected between Gin and Gout pins of the DC/DC converter. Typical value of capacitor C\* is 10µF, typical value of resistor R\* being the equivalent serial resistor ESR of C\*.

Please consult EMI filter FGDS-2A-50V datasheet for further details.

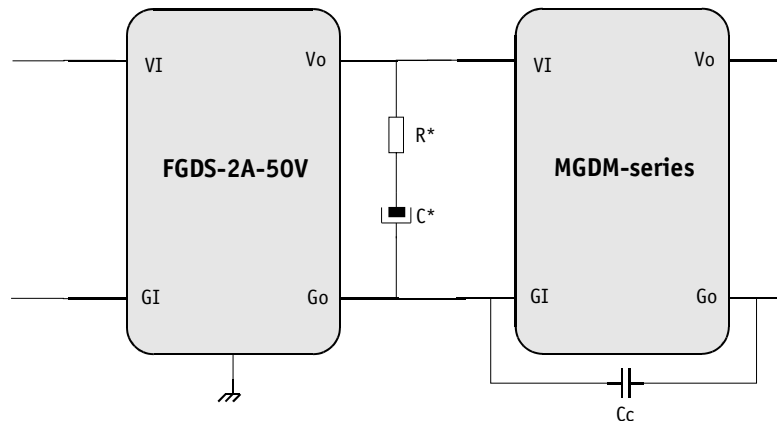

## 4- Lay-out Recommendation

Good printed circuit board layout design is essential to achieve proper EMI performance. The two key areas to consider while laying-out a board are :

- Component and trace routing,
- Grounding design.

### 4-1 Component and trace routing design

The first step while placing the parts is to determine the power flow through the board.

- The optimum design, is from one side of the board to the other, avoiding cross-overs.
- Another possibility is a design where both power input and power output buses are on the same edge of the board (see figure herunder). In such a case, keep as much distance as possible between input and output buses.

The second step is to place the EMI filter as close as possible from the input connector and create a "clean area" including EMI filter and input bus protection.

The third step is to lay-out the power stage "noisy area". If multiple modules are used, it is recommended to leave at least 0.5 inch between each module to avoid radiation from power stage of one module to perturb control stage of the nearby modules and cause cross-talk or jitter.

It is also recommended to place 10nF common mode capacitor with connection between each Gi & Go pins of modules, each module should have its own capacitors. These capacitors should be connected with large copper planes to reduce their ESL.

While routing, do not mix or overlap filtered power traces (e.g. filter's input bus) with unfiltered and noisy power traces (e.g. filter's output bus) as this would dramatically degrade the filter performance. Keep filtered power traces clearly separated and away from unfiltered power traces, for example each on one side of the filter. Also, keep sensitive low level signal traces away from the power bus.

### 4-2 Grounding design

Gaia Converter recommends to use multilayer boards with 3 main grounding areas : chassis ground, Gin ground and Gout ground. Keep the necessary distance for voltage insulation between the different ground areas and vias or through hole pins. Preferably, the grounding areas are plane areas better than grid areas.

The chassis ground plane has to stay in open loop.

The Gin ground plane could be routed in an internal layer to be as homogeneous as possible to provide both a low impedance path and to act as a heatsink for thermal management, preferably on the layer closest to heat generating sources. This plane should be spread all over the board except under filtered (clean area) and sensitive low level areas. It's design should be such that it doesn't create any ground loop. As a consequence, it should also not run under the filtered input bus.

The Gout plane could be routed in an internal layer with all output pin connections.

The «case» pin of the modules (if available) can be connected to the chassis ground plane to achieve a 6 sides shield.

Figure herunder depicts a typical lay-out design.

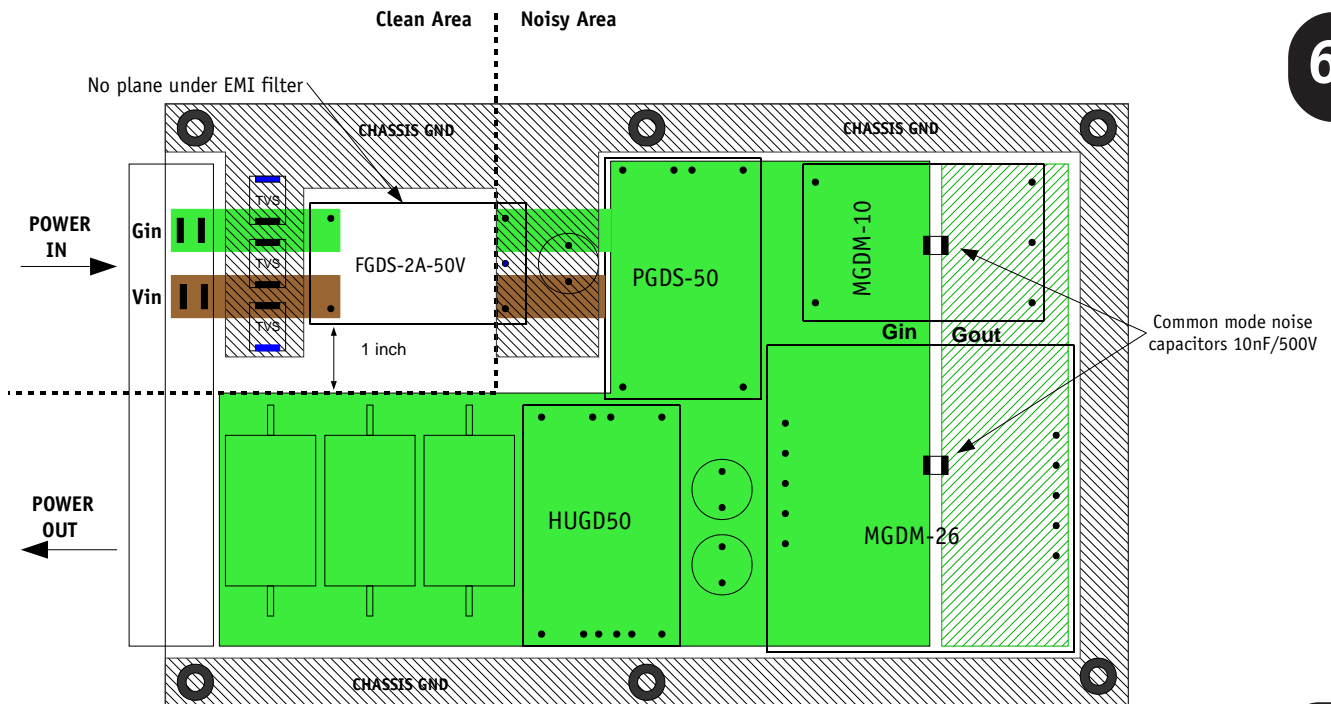

## 5- Output noise

Output noise measurements are difficult to make even under the best conditions. A GAIA Converter dedicated application note "Output ripple and noise" is available for complete information.

### 5-1 Output Noise with GAIA Converter Module Stand Alone

Gaia Converter DC/DC modules the have following maximum output noises.

Type of output	Output noise
3,3 and 5V output	40mVpp up to 20MHz Bandwidth
12V output	50mVpp up to 20MHz Bandwidth
15V output	60mVpp up to 20MHz Bandwidth

### 5-2 Output Noise with Additional External Filter

If the performance is not enough, GAIA Converter has qualified for each DC/DC converter a simple output LC and common mode filter as follow :

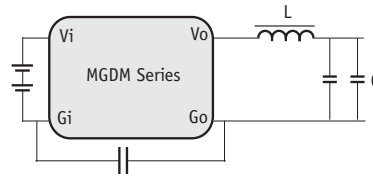

\*Common mode noise capacitance  $C_c = 10nF$

Output current	Less than 1A	1A to 2A	2A to 9A	
Inductance L	4,7 $\mu$ H, D01608C Coilcraft	1 $\mu$ H, D01608 Coilcraft	1 $\mu$ H, D03316 Coilcraft	
Output voltage	0 to 5V	12V	15V	24V
Capacitance C	47 $\mu$ F/10V tantalum 293D Series	22 $\mu$ F/20V tantalum 293D Series	10 $\mu$ F/35V tantalum 293D Series	10 $\mu$ F/35V tantalum 293D Series
Number of capacitance	1 capacitor for each step of 2A	1 capacitor for each step of 1A	1 capacitor for each step of 0.7A	1 capacitor for each step of 0.7A

Such filter will reduce noises down to :

Type of output	Output noise with external filter
3,3 and 5V output	< 10mVpp up to 20 MHz Bandwidth
12V output	< 10mVpp up to 20 MHz Bandwidth
15V output	< 10mVpp up to 20 MHz Bandwidth

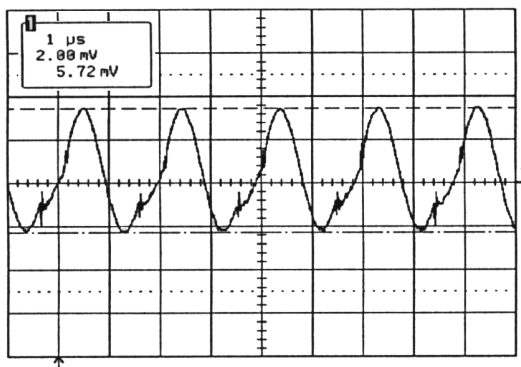

MGD8-043-C with external filter

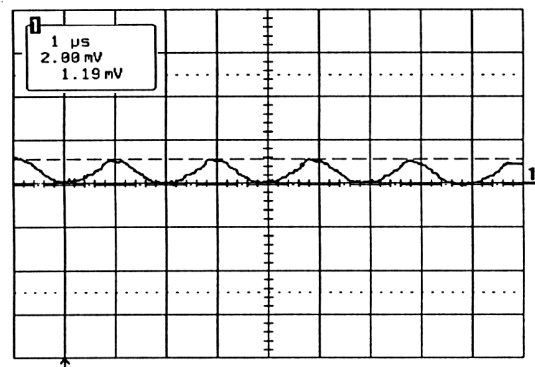

MGD8-10-J-C with external filter



## 6- Compliance with Environmental Condition Requirements

Avionics and military electronic systems shall sustain a high level of environmental conditions depending on their use/location.

The levels are defined in different standards, among which the most frequently used are :

- The RTCA/DO-160C standard : “Environmental Conditions and test Procedures for Airborne Equipment”.
- The US MIL-STD-810 standard : “Environmental Test Method”.
- The US MIL-STD-202 standard : “Environmental Test Method”.

- The US MIL-STD-883 standard : “Screening Procedures”.
- The French GAM-EG 13B standard : “Essais de comptabilité à l’environnement climatique, mécanique”
- The UK BS3G100 standard : “Environmental Conditions Test Method”.

To verify the suitability of GAIA Converter modules, a complete qualification test program has been undertaken by an independent laboratory part of the French Defense Agency CELAR which includes :

T ests	Standards	GAIA Converter DC/DC module qualification
Life at high temperature	per MIL-STD-202G Method 108A	Operation : 1.000 hrs @ +105°C case Storage : 1.000 hrs @ +125°C ambient
Low temperature	per MIL-STD-810E/G Method 502.3/502.5	Storage : 1.000 hrs @ -55°C ambient
Temperature cycling	per MIL-STD-202A Method 102A	Number of cycles : 200 Temperature change : -40°C / +85°C Transfert time : 40 min. Steady state time : 20 min
Temperature shock	per MIL-STD-202G Method 107G	Number of shocks : 50 Temperature change : -55°C / +105°C Transfert time : < 10 sec Steady state time : 30 min
Low Pressure (Altitude)	per MIL-STD-810E/G Method 500.3/500.5	40.000ft, unit functioning 1.000ft/min to 70.000ft,unit functioning
Humidity (Cyclic)	per MIL-STD-810E/G Method 507.3/507.5	Damp heat : 60% to 88% relative humidity Cycle I : (31°C to 41°C) : 240Hrs
Humidity (Steady state)	per MIL-STD-202G Method 103B	Damp heat : 93% relative humidity Temperature : 40°C Duration : 56 days
Salt spray	per MIL-STD-810E/G Method 509.3/509.5	Temperature : 35°C Duration : 48 hrs
Vibration Frequency range Acceleration	per MIL-STD-810D/G Method 514.3/514.6	10 cycles in each axis frequency : 10 to 60Hz/60 to 2 KHz acceleration : 0.7mm/10g
Shock (Half sinus) Peak acceleration Duration	per MIL-STD-810D/G Method 516.3/516/6	3 shocks in each axis Peak acceleration : 100g duration : 6ms
Bumps	per MIL-STD-810D/G Method 516.3/516.6	2000 bumps in each direction duration : 6ms peak acceleration : 40g

## 7- Thermal Management

GAIA Converter modules are given for a maximum case temperature of 105°C. This case temperature corresponds to an internal component temperature far below (design derating) their maximum junction temperature.

Usually for designer, environment is explained with ambient temperature. To rapidly check if this ambient condition is compliant with the maximum case temperature, the first step is to find the power dissipated in the converter, this value is calculated as follow :

$$P_{\text{dissipation}} = P_{\text{out}} / \text{efficiency} - P_{\text{out}}$$

(Efficiency is given for each module in the technical datasheet )

GAIA Converter provides for each Hi-Rel converter the thermal resistance Rth case ambient by watt dissipated so the maximum ambient temperature is given with the formula :

$$T_{\text{ambient}} = 105^{\circ}\text{C} - P_{\text{diss}} * R_{\text{th}}$$

Where Tambient is given in °C

An example is given with a MGDM-10 module, 10W converter, 86% efficiency used with 10W power and having 12°C/W of Rth in worst condition (still air) will be able to be used at :

$$T_{\text{ambient}} = 105 - ( 10 / 86\% - 10 ) * 12 = 85^{\circ}\text{C}$$

If calculated ambient temperature is not compliant with the requirement an additional thermal path should be found to lower the thermal resistance with :

- Heat sink
- Forced air cooling
- Larger area of circuit board metallization.

A method of removing heat recommended by GAIA Converter is conductive heat sink through direct contact with the module case.

An example is given in the following application where heat sink is provided by the top case in conductive metal.

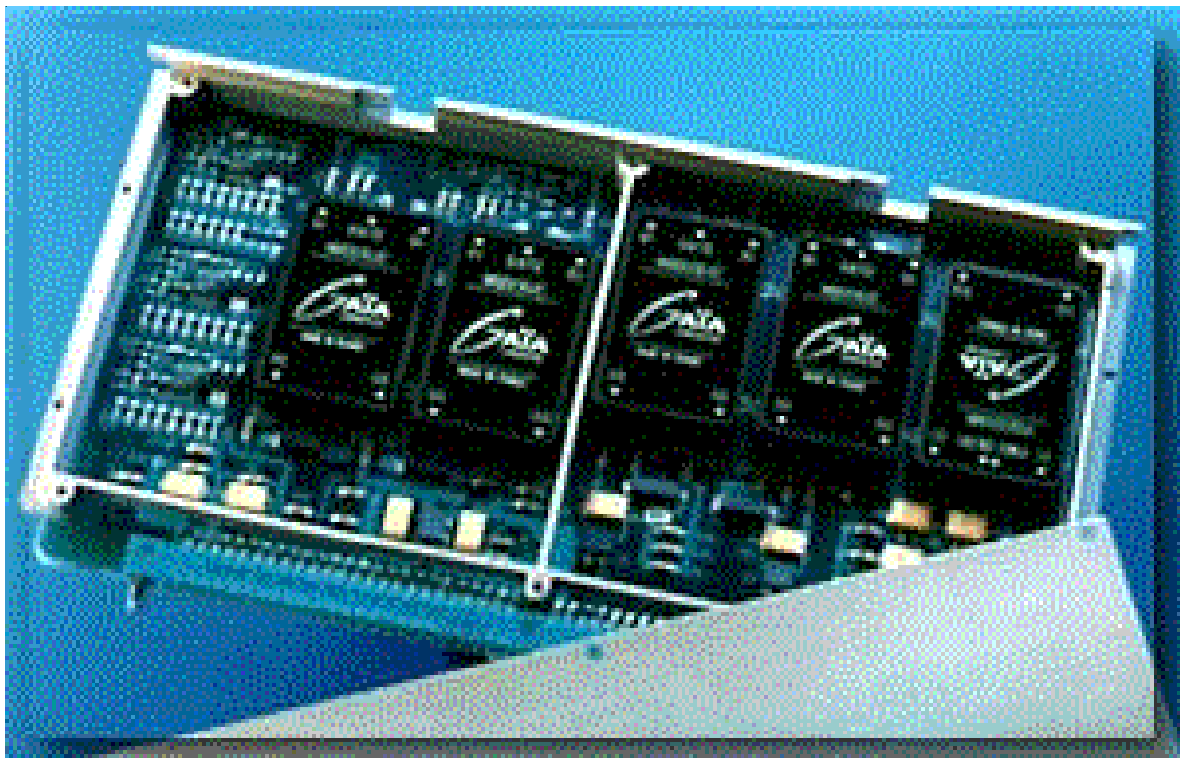



Represented by :

Information given in this datasheet is believed to be accurate and reliable. However, no responsibility is assumed for the consequence of its use nor for any infringement of patents or other rights of third parties which may result from its use. These products are sold only according to GAIA Converter general conditions of sale, unless otherwise confirmed by writing. Specifications subject to change without notice.