

DC/DC CONVERTER
12:1 Ultra wide Input Range
IEC-62368-1 3KVAC Reinforced Insulation

Description

The MGRI-20-R series features a range of high density board mounted isolated dc/dc converters. With a 12:1 ultra-wide input voltage range and reinforced isolation (4252V dc test) the MGRI-20-R delivers a double 10W output channel. Available in 2x 5, 2x12, or 2x15 volts outputs, each model features a trim function to adjust the output voltages in a 80/110% range. The converter embeds several functions as soft start, over temperatures and output overload protection. The converter comes in a low profile fully potted metallic case.

Featuring

- IEC-62368 3kV ac Reinforced Insulation
- EN50155 applications
- Ultra wide input range with UVLO trim
- Efficiency up to 87%
- 80% to 110% trimmable output
- Fully hermetic metallic case 35x30x 10mm



Fields of Application

Transportation
 Industrial

Selection Guide

Part Number	Permanent Input Voltage (Vdc)	Output Power* (W)	Nominal Output Voltage (Vdc)	Output Current (Vdc)
MGRDI-20-R-C	12-160	20	2X5	2X2
MGRDI-20-R-E	12-160	20	2X12	2X0.85
MGRDI-20-R-F	12-160	20	2X15	2X0.675

*with derating at low input voltage

1-ELECTRICAL SPECIFICATIONS

Data are valid at +25°C, unless otherwise specified, U_i min. U_i nom. U_i max. stand for input voltage, (respectively minimum, nominal, and maximum)

Parameter	Conditions	Limit	Units	Value
ABSOLUTE MAXIMUM RATING				
Maximum Input Voltage	1 s	Maximum	Vdc	165
Maximum Input Voltage	100 ms	Maximum	Vdc	176
Case temperature	Operating	Min. / Max.	°C	-55 / 105
INPUT				
Nominal Input Voltage Range	Full temperature range	Nominal	Vdc	12-140
Nominal Batteries Voltage	Full temperature range	Nominal	Vdc	37.5-24-48-72-96-110
Undervoltage lock-out (UVLO)	Turn-on voltage turn-off voltage	Nom.-Max.	Vdc	12-12.5 10-10.5
Start-up time	U_i nom resistive load	Maximum	ms	30
Reflected ripple input current	U_i nom. Full load Peak to Peak BW=20MHz	Maximum	%	10%*
No load input Power	U_i nom.	Maximum	W	0.9
Input power in inhibit mode	U_i nom.	Maximum	W	0.5
Input power in short circuit mode	U_i nom.	Maximum	W	12
OUTPUT				
Output power	12Vdc < U_i < 36Vdc 36Vdc ≤ U_i < 140Vdc**		W	15 20
Channel Power Unbalance	As function of total power for each	Maximum	%	10/90
Set Point accuracy	U_i nom. @75% load output in parallel	Maximum	%	+/- 2
Output load regulation	U_i nom. output in parallel	Maximum	%	+/-0.1
Output total regulation (Line + Load +Thermal)	U_i min. To U_i max 10% to full load ⁺	Maximum	%	+/- 2
Outputs cross-regulation	U_i nom. Load : 100% on one output, 25% to 100% on the other	Maximum	%	+/- 6
Output ripple voltage C output (5V) E output (12V) F output (15V)	U_i min. To U_i max 10% load to full load	Typical	mVpp	240 240 300
Output voltage trim Range	% of nominal output voltage	Nom.-Max.	%	80 -110
Power efficiency	U_i nom. 75% load	Typical	%	87

* With 100µF on input for U_i below 36Vdc and 47µF on input for U_i > 36Vdc ** Ruvlo mandatory ⁺ below 10% load, +/- 2% can be achieved with additional output capacitor

1-ELECTRICAL SPECIFICATIONS

Data are valid at +25°C, unless otherwise specified, U_i min. U_i nom. U_i max. stand for input voltage, (respectively minimum, nominal, and maximum)

Parameter	Conditions	Limit	Units	Value
Switching frequency	U_i min. to max. 0% to full load	Nominal (+/-15%)	KhZ	270
EMC Compliance	With additional filter (Or FLHGI90)		-	EN 550121
IEC62368 Compliance	Input/output case/output		-	Reinforced Isolation
Isolation Strength⁽¹⁾⁽²⁾	Input/output case/output (IEC62368)	Minimum	V Ac	3000
Isolation Strength	Input/case	Minimum	Vdc	1500

Railway Standard Bus Voltage Compliance

EN50155	Nominal / Surge Voltage 24V / 33.6 Vdc 48 / 67.2 Vdc 75 / 100.8 Vdc 96 / 134.4 Vdc 110 / 155.4 Vdc	-	-	Stand-alone Compliant
NF F01-510	Nominal / Surge Voltage 24V / 40 Vdc 72 / 115 Vdc 110 / 176 Vdc	-	-	Stand-alone Compliant
RIA12	Nominal / Surge Voltage 24V / 33.6 Vdc 37.5 / 131.3 Vdc 48 / 168 Vdc 72 / 252 Vdc 96 / 336 Vdc 110 / 385 Vdc	-	-	Stand-alone Compliant Compliant with additional limiter (FLHGI90)
Maximum capacitive load C output E & F output	U_i nom.	Maximum	μ F	>40 000
Over Current Protection level (OCP level)	As function of nominal output current	Minimum Typical Maximum	%	105 160 400
On/off enable voltage	U_i nom.	Minimum Maximum	Vdc	2.5 3.3
On/off enable delay	U_i nom. (W/o output cap.)	Maximum	ms	30
On/off disable voltage	U_i nom.	Minimum Maximum	Vdc	0 0.5
On/off disable delay	U_i nom. (W/o output cap.)	typical	μ s	100

2-RELIABILITY

Parameter	Conditions	Unit	Value
Mean Time Between Failure (MTBF) according to TELCORDIA issue3	Ground Benign 25°C amb.	Khr (Kilo hours)	18 000
	Ground Fixe 25°C amb.		8 300
Mean Time Between Failure (MTBF) according to MIL-HDBK217-F	Ground Benign 25°C amb.	Khr (Kilo hours)	2 800

3-THERMAL MANAGEMENT

Case temperature range	Unless otherwise specified	Mini.Max.	°C	-40 to 105
Storage temperature range		Mini.Max.	°C	-40 105
Case to Air thermal resistance		Typical	°C/W	16

The converter thermal management can be achieved following 3 different ways:

Free air cooling : the converter self thermal resistance (R_{th}) permits operation without additional cooling device.

Cooling through an heat-sink : the heat-sink is applied to the converter top case (Gaia-converter logo being a laser marking, it will not disturb thermal transfert) through a thermal interface (gap-pad). This allows to reduce the total thermal resistance from case to ambient (R_{th}), resulting of the combination of case thermal resistance, gap pad thermal resistance, and heat-sink thermal resistance. The max ambient temperature is given by :

$$T_{amb} = T_c - P_o * \left(\frac{1}{eff} - 1 \right) * R_{th}$$

T_{amb} = max ambient temp.

T_c = max case temp.

Eff = efficiency

R_{th} = thermal resistance of assembly case plus heat-sink to ambient

the diagram below shows various ambient temperature derating curves according to different final thermal resistance R_{th} .

Chassis mount: converter is applied to the chassis surface through a dedicate thermal interface (Gap-pad). The maximum operation temperature will be given with the following formula :

$$T_{amb} = T_{ch} - P_o * \left(\frac{1}{eff} - 1 \right) * R_{th}$$

T_{amb} = max ambient temp.

T_{ch} = max chassis temp.

Eff = efficiency

R_{th} = thermal resistance of assembly case plus gap-pad

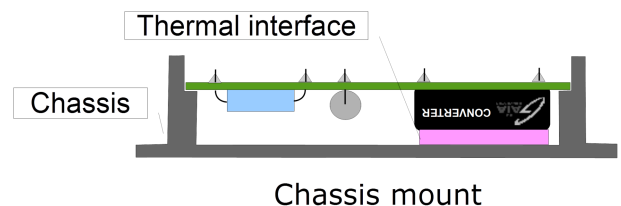
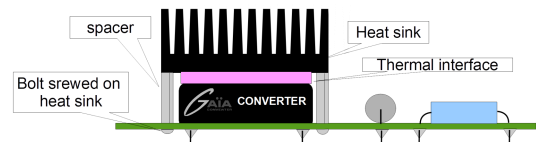
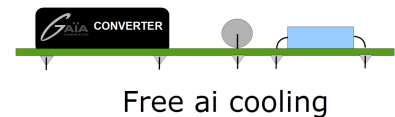

4-APPLICATIONS

4.10-UVLO FUNCTION

An input undervoltage protection will inhibit the module when input voltage drops below the under voltage lock down voltage (UVLO) (see section 1 for value) and restores to normal operation automatically when the input voltage rises above the turn-on threshold.

The UVLO voltage can be adjusted using an external resistor (R_{uvlo}) connected between pins UVLO and G_i . This value can be adjusted in order to allow converter to shut down properly depending on the input bus (or battery) voltage value. R_{uvlo} can be determined using the following formula:

$$R_{uvlo} = \frac{110}{(V_{uvlo} - 8.51)} - 1$$

R_{uvlo} = trimming resistance

V_{uvlo} = desired **turn-on** voltage

Values are in KOHms

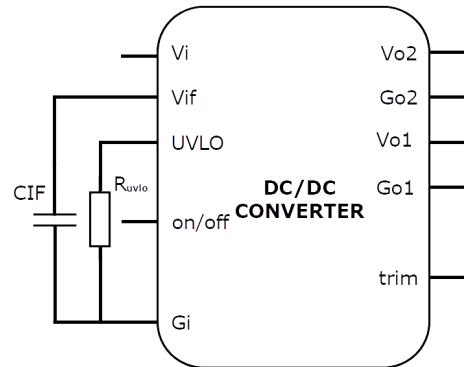

4.11-Output Power derating

When the converter is operated with an input voltage below 36Vdc in steady state or in transient mode, the output power needs to be reduced according to the opposite graph. The red hatched area shows a forbidden area.

It is highly recommended when operating above 36Vdc to set the UVLO voltage at a level close below 36Vdc in order to disable the converter in case the input voltage remains constantly between 12 and 36Vdc. The recommended R_{uvlo} value is given here below:

$R_{uvlo} = 3.3K$

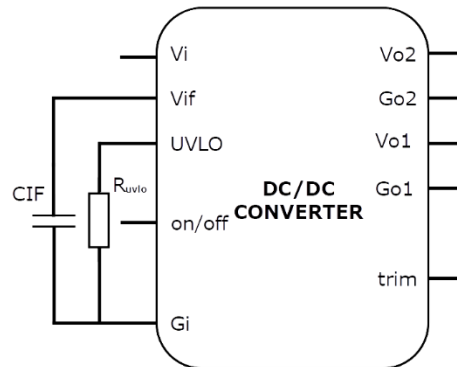

Output Power Derating vs input voltage

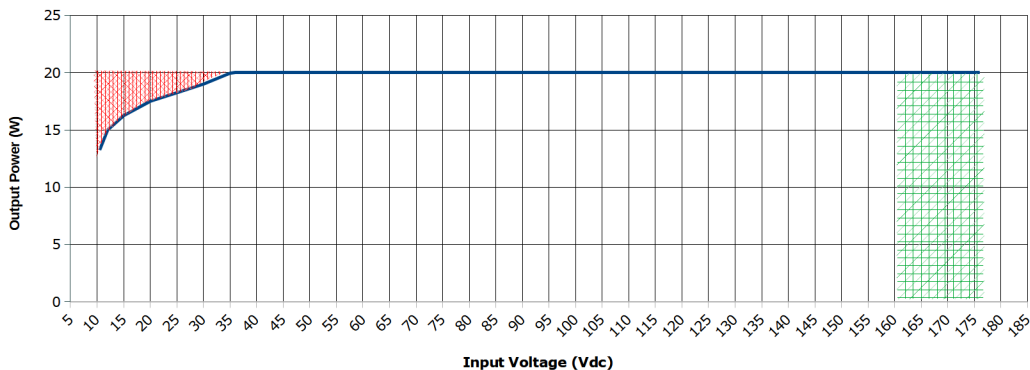

4-APPLICATIONS

4.12-OUTPUT CONNECTIONS

The 2 isolated output channels can be connected in 4 different ways:

- Connection in parallel mode
- Connection in serial mode
- Connection for symmetrical channels
- Connection for independent channels

Connection in parallel mode:

In this mode of connection, the converter delivers one single full power output channel of nominal voltage. The output voltage can be trimmed up or down following the connection diagram shown on paragraph "output voltage trim function".

The parallel mode connection diagram is shown opposite. The parallel mode connection is used for most of the specifications given in table section 1.

Connection in serial mode:

In this mode of connection, the converter delivers one single full power output channel of twice the nominal voltage. The output voltage can be trimmed up or down following the connection diagram shown on paragraph "output voltage trim function". The serial mode connection diagram is shown opposite, it is recommended to use Channel one (Vo1/Go1) as low side part of output voltage, in order to keep Go1 as 0V reference.

Connection for symmetrical channels:

In this mode of connection, Vo2 is connected to Go1 in order to get a common 0v reference. In this case Vo1 delivers the nominal output voltage, while the negative value of nominal output voltage is present on Vo2.

The Connection for symmetrical channels diagram is shown opposite. The output voltage can be trimmed up or down following the connection diagram shown on paragraph "output voltage trim function". In this mode of connection, the output channels are subject to cross regulation.

Connection for independent channels:

When the 2 output channels are not interconnected each other, the converter delivers 50% of total power on each channel. This 50% power ratio can go up to 20% / 80% provided the channel 1 (Vo1/Go1) delivers the highest power level. The Connection for independent channels diagram is shown opposite. The output voltage can be trimmed up or down following the connection diagram shown on paragraph "output voltage trim function". In this mode of connection, the output channels are subject to cross regulation deviation.

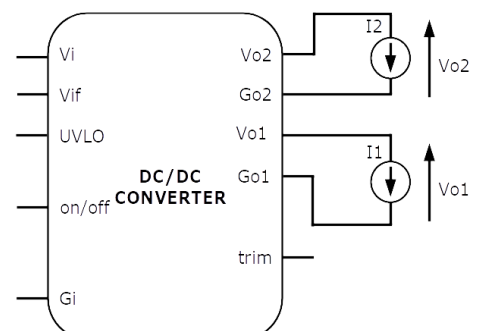
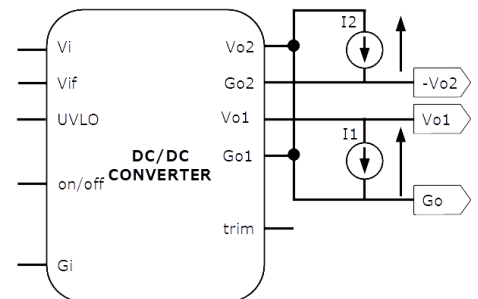
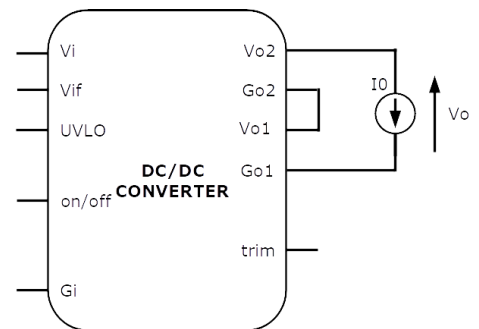
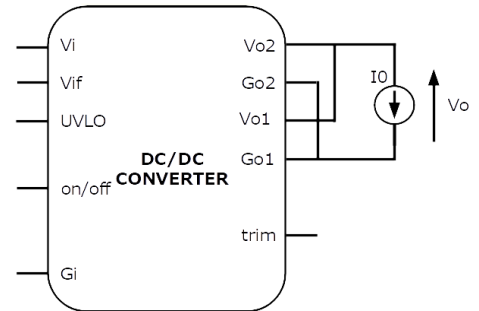

4-APPLICATIONS

4.13-CROSS REGULATION

When the converter is operated for 2 symmetrical channels or independent channels, some precautions need to be taken.

Minimum load on channel 1:

Please note that regulation is achieved through output V01/G01 named primary output. When the 2 channels output are not connected in parallel configuration, and loads are unbalanced, V01/G01 has to be loaded at least at 10% of total converter maximum power, to insure proper operating.

Cross regulation:

The V02/G02 output named secondary output may stay unloaded, but in that case its regulation may drift up as shown in curve opposite. There is no minimum load when the two outputs are connected in parallel or balanced serial connection.

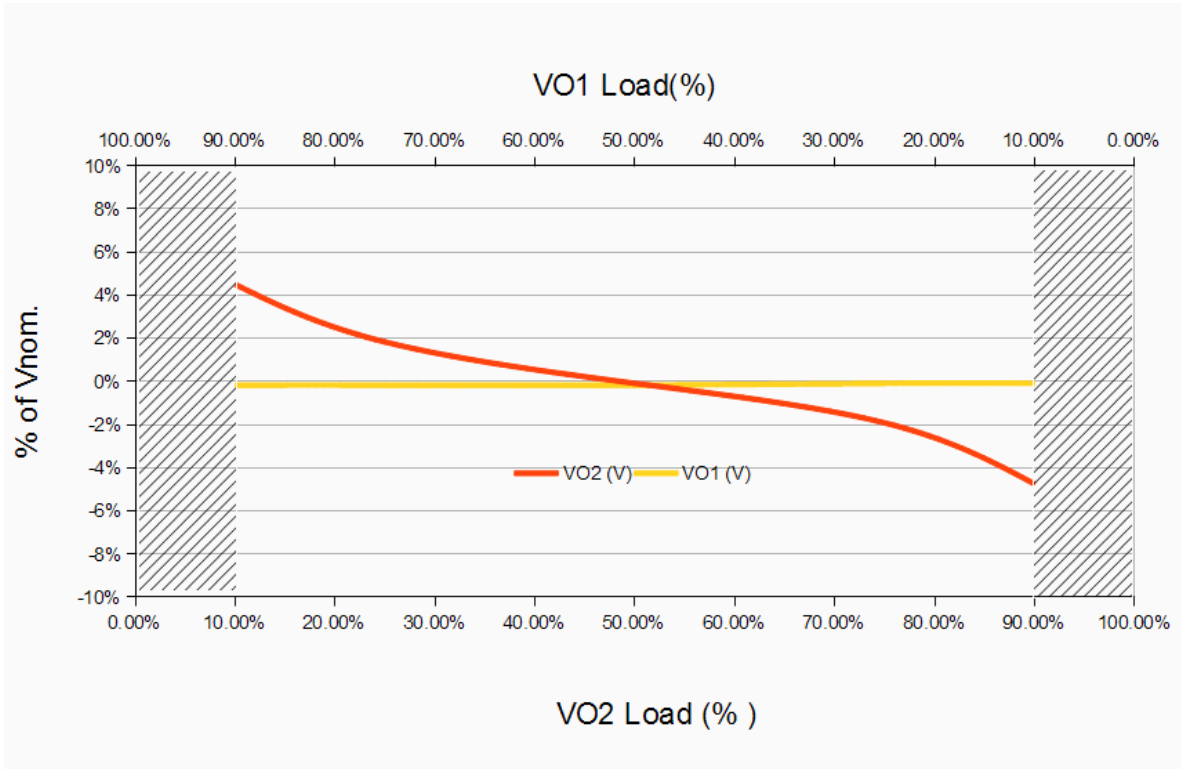
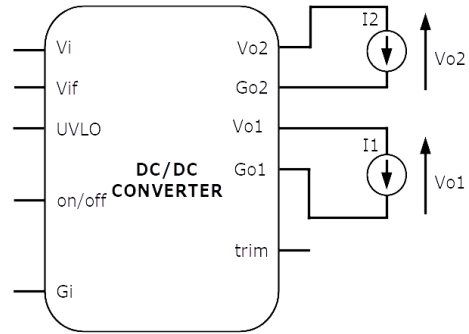

4-APPLICATIONS

4.14-OUTPUT VOLTAGE TRIM FUNCTION

The output voltage V_o may be trimmed using an external trimmer or a fixed resistor. The resistor value can be determined by the formulas here after*.

Trim Up Function

The R_d resistor value can be evaluated with the following theoretical formula.

$$R_u = \frac{4.7(V_{onom} - 1.225) * V_{onom}}{(V_o - V_{onom})} - 0,27$$

where : R_u = trim-up resistor in **K Ω**
 V_{onom} = nominal output voltage
 V_o = desired output voltage.

Trim Down Function

The R_d resistor value can be evaluated with the following theoretical formula.

$$R_d = \frac{4.7 \left(\frac{V_{onom}}{1.225} - 1 \right) (V_o - 1.225)}{V_{onom} - V_o} - 0.27$$

where : R_d = trim up resistor in **K Ω**
 V_{onom} = nominal output voltage
 V_o = desired output voltage.

*For slight trimming value, the resistor value being very large can be replaced by a resistor bridge (please consult factory)

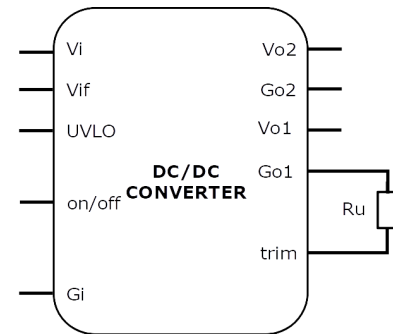
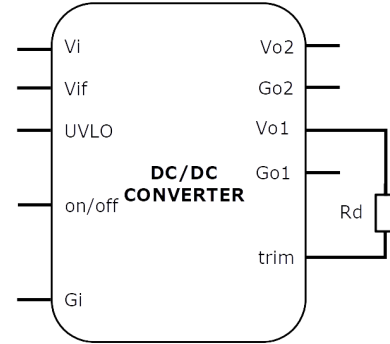

4.15-ON/OFF

The control pin (On/Off) can be used for applications requiring On/Off operation. This may be done with an open collector transistor, a switch, a relay or an optocoupler. Several converters may be disabled with a single switch by connecting all (On/Off) pins together.

- The converter is disabled by pulling low pin (On/Off).
- No connection or high impedance on pin (On/Off) enables the converter.

When (On/Off) is released the converter will restart within the specified start up time.

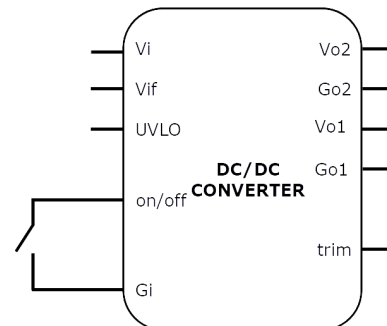

4-APPLICATIONS

4.16-INPUT SECTION STABILITY

Stability at low input voltage :

When converter is used with low voltage input bus (typically 24V) the input bus impedance should be lower than the dc/dc input impedance to avoid stability issues. To avoid the risk of oscillation it is recommended to populate a damped capacitive network on VIF pin.

The damped capacitive network is composed of 2 capacitors and one resistor that need to be connected as close as possible to the VIF and GI pins (see diagram opposite), with very low impedance connections.

The ceramic capacitor isolation voltage needs to be overrated to guarantee the capacitive value will not be deprecated at low temperature.

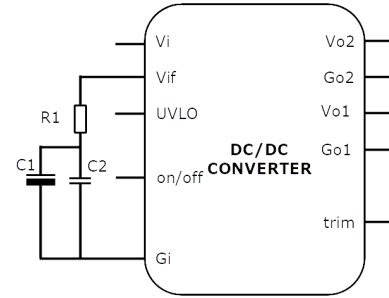

Input Bus V	C1 (aluminum)	C2 value (Ceramic)	R1 mΩ	R1 power W
12	33μF/250V	4x560nF/500V	150	4W
24	33μF/250V	4x560nF/500V	150	2.5W

Stability at high input voltage :

If the converter is supplied by a higher voltage (typically 36V 48V or more), it is possible to reduce the VIF network to a simple ceramic capacitor (CIF), provided the UVLO limit is trimmed above 30Vdc, (see diagram opposite).

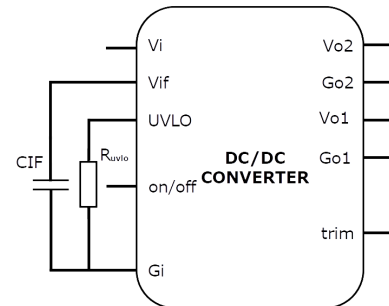

CIF value (Ceramic)	Ruvlo KΩ
4x560nF/500V	150

4.17-TEST CIRCUIT

To operate the converter with no risk of malfunction or damage, it is mandatory to connect at least 2 common mode capacitors across input/output Vi/Vo and Gi/Go.

For a better common mode noise mitigation, it is possible to consider the configuration with 4 common mode capacitors connecting hot lines to chassis (see opposite figure). The capacitors value can range from 4.7 to 10nF .

The capacitors can be from Y2/Y3 class if reinforced isolation is not mandatory, in the otherwise, the capacitors need to be from Y1 class with isolation rated to 2 time the application operating voltage. (MDY1472MY5UD from Vishay, or C951U472MVDDBA7317 from Kemet)

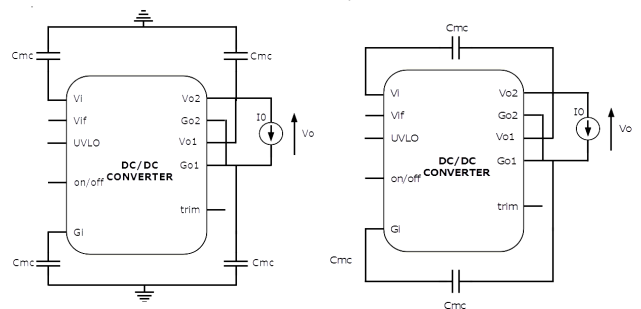

4-APPLICATIONS (continued)

4.18-OVER CURRENT PROTECTION

The converter Series features an over-current protection circuit that detects short circuit or over current and protects the module according to the hiccup graph (opposite). The maximum detection current I_d is depending on input voltage V_{in} and temperature. When OCP is triggered, the converter falls into hiccup mode, testing periodically if the overload is still present. The module restarts automatically in soft-start to normal operation when overcurrent is removed. T_d (detection time) and T_h (hiccup period) are depending on V_{in} and temperature.

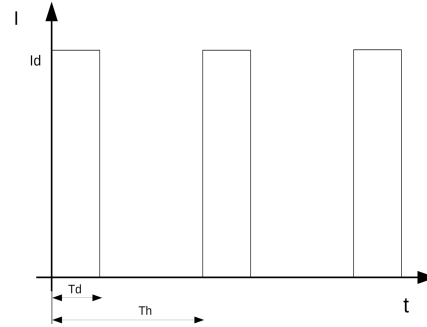

4.19-EMI COMPLIANCE

EN55022 Class B conducted EMI level can be met using an input filter with components rated accordingly input voltage and output power. Please consult FilterEN50155rev(x).pdf on Gaia-converter website for more information.

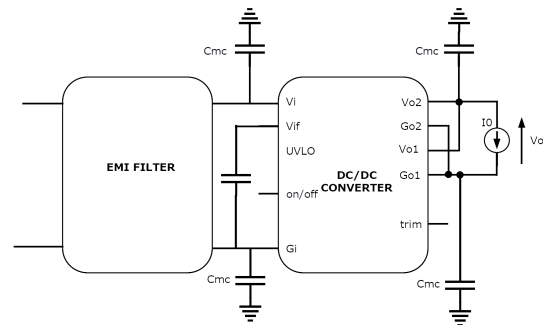

4-APPLICATIONS (continued)

4.20-MECHANICAL DRAWINGS

Dimensions are given in mm [inch].
 General tolerance is +/-0.2mm [+/-0.008"] unless otherwise indicated.
 All dimensions specified "min" or "max" are not subjected to the general tolerance.

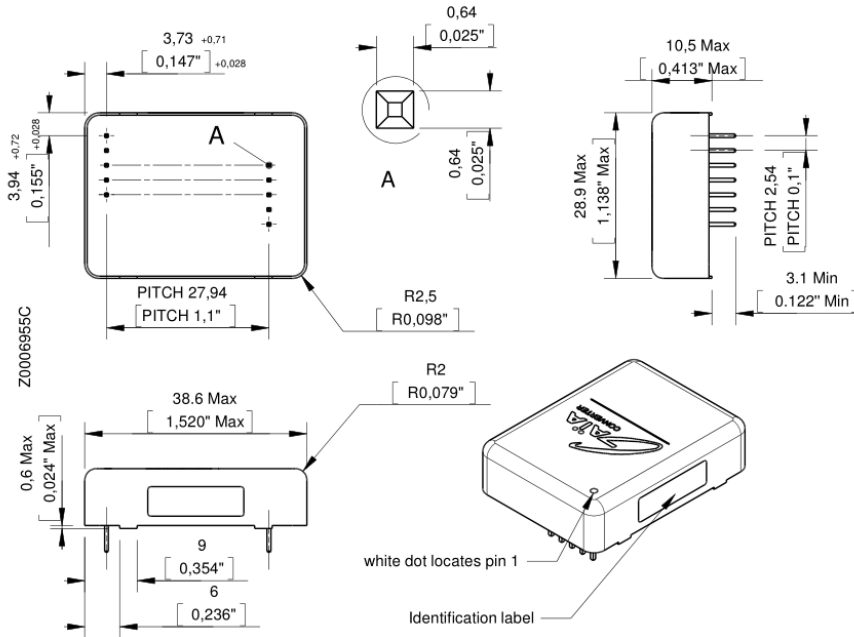

4.21-CONNECTION-PRODUCT MARKING

Marking :
 Company logo.
 Module reference : MGRDx-20-»X»-»Y».
 Date code : year and week of manufacturing, suffix, /option.

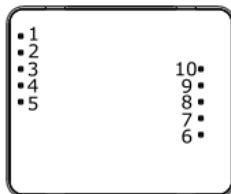

Pin	Function
1	On / Off
2	UVLO
3	-Input (Gi)
4	VIF
5	+Input (Vi)
6	+Output 2 (Vo2)
7	-Output 2 (Go2)
8	+ Output 1 (Vo1)
9	- Output 1 (Go1)
10	Vtrim

Material : Metallic case black anodized coating.
 Pin : Flash gold plating over nickel underplate.



MGRI-20-R 20W POWER



Information given in this datasheet is believed to be accurate and reliable. However, no responsibility is assumed for the consequence of its use nor for any infringement of patents or other rights of third parties which may result from its use. These products are sold only according to GAIA Converter general conditions of sale, unless otherwise confirmed by writing. Specifications subject to change without notice.