



Industrial DC/DC CONVERTER MGDI-04 Standard Input : 4W POWER

Industrial Grade ■

**2:1 Standard Input
Single & Bi Outputs
Metallic Case - 1 500 VDC Isolation**



- Low profile : 0,3 " (7.5mm)
- Nominal power of 4 W without derating
- Wide temperature range : -40°C/+95°C case
- High efficiency up to 80 %
- Soft start
- Galvanic isolation 1.500 VDC
- Integrated LC EMI filter
- Permanent short circuit protection
- Standard pin out DIL24 8 pins
- No optocoupler for high reliability
- RoHS process

1-General

The MGDI-04 series is a full family of DC/DC power modules designed for use in distributed power architecture and are particularly suitable for mobile or ground fixed applications in transportation, industry and telecommunications areas. These modules use a high frequency fixed switching technic at 480 KHz providing excellent reliability, low noise characteristics, high power density and a low profile package. Standard models are available with nominal input voltages as 5 or 24 volts in range of 4,5-5,5 or 18-36 volts. The series include single and bi output voltage choices of 3,3, 5, 12, 15, +/-5, +/-12 or +/-15 volts.

No external heatsink is required for the MGDI-04 series to supply 4W output power over the case temperature range of -40°C up to 95°C. The MGDI-04 series is designed in conformity with safety standards EN60950 and UL1950.

All the modules are designed with LC network filters to minimize reflected input current ripple and output voltage ripple according to EN55022 and FCC Part 15J standard.

The modules include a soft-start, a permanent short circuit protection and an output overvoltage protection to ensure efficient module protections. The soft-start allows current limitation and eliminates inrush current during start-up. The short circuit protection completely protects the modules against short-circuits of any duration by a shut-down and restores to normal when the overload is removed.

The design has been carried out with surface mount components and is manufactured in a fully automated process to guarantee high quality. Each module is tested and burned in with a GAIA Converter automated test equipment.

5

2-Product Selection

Single output model : MGDSI - 04 - -
 Bi output model : MGDBI - 04 - -

Input Voltage Range
Permanent
C : 4,5-5,5 VDC
I : 18-36 VDC

Output
B : 3.3 VDC
C : 5 VDC or +/-5VDC
E : 12 VDC or +/-12VDC
F : 15 VDC or +/-15VDC

Options :
/M : option for On/Off function

2- Product Selection (continued)

Input range	Output	Current	Reference	Options
4.5-5.5 VDC	3,3 VDC	1 000 mA	MGDSI-04-C-B	/M
4.5-5.5 VDC	5 VDC	800 mA	MGDSI-04-C-C	/M
4.5-5.5 VDC	12 VDC	330 mA	MGDSI-04-C-E	/M
4.5-5.5 VDC	15 VDC	260 mA	MGDSI-04-C-F	/M
4.5-5.5 VDC	+/- 5 VDC	+/- 400 mA	MGDBI-04-C-C	/M
4.5-5.5 VDC	+/- 12 VDC	+/- 165 mA	MGDBI-04-C-E	/M
4.5-5.5 VDC	+/- 15 VDC	+/- 130 mA	MGDBI-04-C-F	/M
18-36 VDC	3,3 VDC	1 000 mA	MGDSI-04-I-B	/M
18-36 VDC	5 VDC	800 mA	MGDSI-04-I-C	/M
18-36 VDC	12 VDC	330 mA	MGDSI-04-I-E	/M
18-36 VDC	15 VDC	260 mA	MGDSI-04-I-F	/M
18-36 VDC	+/- 5 VDC	+/- 400 mA	MGDBI-04-I-C	/M
18-36 VDC	+/- 12 VDC	+/- 165 mA	MGDBI-04-I-E	/M
18-36 VDC	+/- 15 VDC	+/- 130 mA	MGDBI-04-I-F	/M

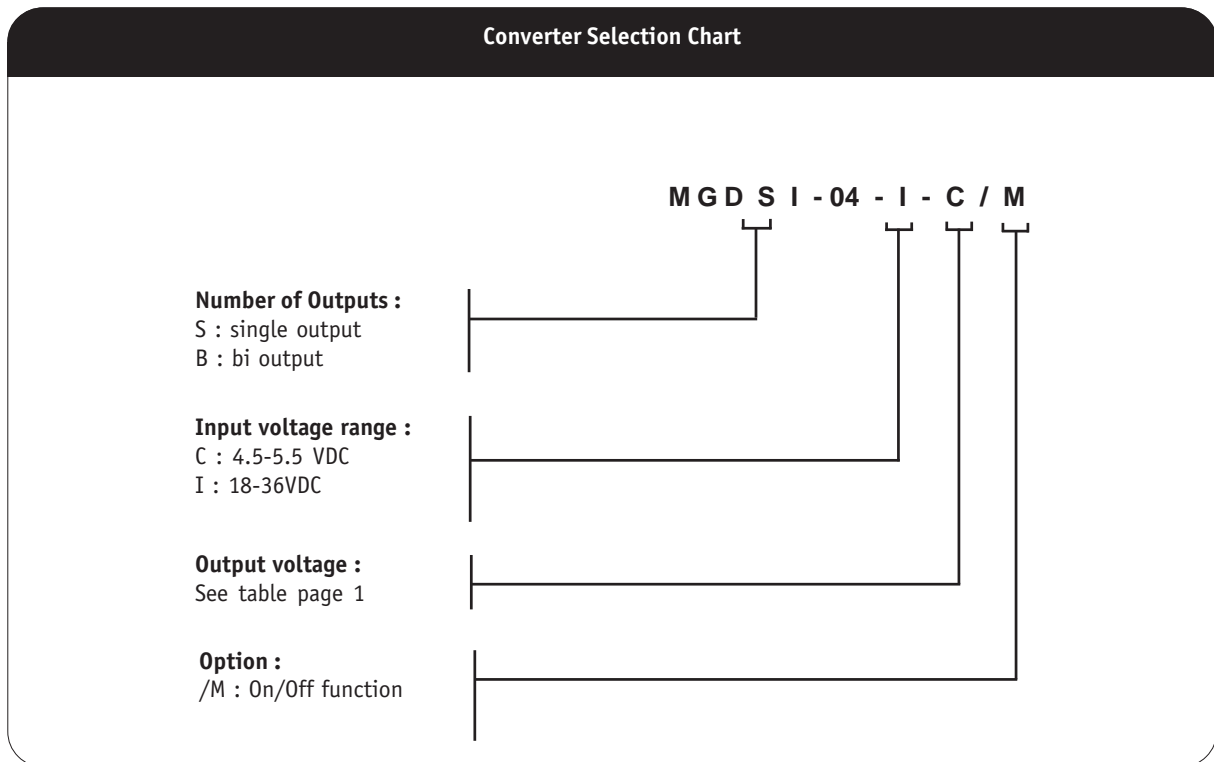

3- Electrical Specifications

Data are valid at +25°C, unless otherwise specified.

Parameter	Conditions	Limit or typical	Units	Single Output MGDSI-04	
				04 - C	04 - I
Input					
Nominal input voltage	Full temperature range	Nominal	VDC	5	24
Permanent input voltage range (Ui)	Full temperature range	Min. - Max.	VDC	4,5- 5,5	18- 36
Reflected ripple current	Ui nominal, full load at switching freq. BW = 20MHz Decoupling capacitor 10µF	Typical	mApp	50	30
Input current in short circuit mode (Average)	Ui nominal Short-circuit	Maximum	mA	50	30
No load input current	Ui nominal No load	Maximum	mA	50	30
Output					
Output voltage	Ui min. to max.	Nominal	VDC	3,3	3,3
		Nominal	VDC	5	5
		Nominal	VDC	12	12
		Nominal	VDC	15	15
Set Point accuracy	Ambient temperature : +25°C Ui nominal, 75% load	Maximum	%	+/- 2	+/- 2
Output power	At 105°C baseplate Ui min. to max.	Maximum	W	4	4
Output current	Full temperature range Ui min. to max.	Maximum	mA	1 000	1 000
3,3V output		Maximum	mA	800	800
5V output		Maximum	mA	330	330
12V output		Maximum	mA	260	260
15V output					
Ripple output voltage *	Ui nominal Full load BW = 20MHz	Maximum	mVpp	50	50
3,3V and 5V output		Maximum	mVpp	100	100
12V output		Maximum	mVpp	150	150
15V output					
Line regulation	Ui min. to max. Full load	Typical	%	+/- 1	+/- 1
Load regulation **	Ui nominal 25% to full load	Typical	%	+/- 2,5	+/- 2,5
Efficiency	Ui nominal Full load	Typical	%	76	78
Maximum admissible Capacitive load	Ui nominal Full load Per output	Maximum	µF	1 000	1 000
3,3V and 5V output					
12V and 15V output		Maximum	µF	47	47

Note * : The ripple output voltage is the periodic AC component imposed on the output voltage, an aperiodic and random component (noise) has also to be considered. This noise can be reduced by adding an external capacitor (typically 10µF/rated voltage depending on isolation requirement) connected between the pin *Gi* and the pin *Gout* of the converter. This capacitor should be layed-out as close as possible from the converter.

Note ** : For load regulation characteristics from 0% to full load, please contact factory.

3- Electrical Specifications (continued)

Data are valid at +25°C, unless otherwise specified.

Parameter	Conditions	Limit or typical	Units	Bi Output MGDBI- 04	
				04 - C	04 - I
Input					
Nominal input voltage	Full temperature range	Nominal	VDC	5	24
Permanent input voltage range (Ui)	Full temperature range	Min. - Max.	VDC	4,5- 5,5	18- 36
Start up time*	Ui max. Nominal output Full load : resistive	Maximum*	ms	200	200
Reflected ripple current	Ui nominal, full load at switching freq. BW = 20MHz Decoupling capacitor 10µF	Typical	mApp	50	30
Input current in short circuit mode (Average)	Ui nominal Short-circuit	Maximum	mA	50	30
No load input current	Ui nominal No load	Maximum	mA	50	30
Output					
Output voltage	Ui min. to max.	Nominal	VDC	+/- 5	+/- 5
		Nominal	VDC	+/- 12	+/- 12
		Nominal	VDC	+/- 15	+/- 15
Set Point accuracy	Ambient temperature : +25°C Ui nominal, 75% load	Maximum	%	+/- 2	+/- 2
Output power	At 105°C baseplate Ui min. to max.	Maximum	W	+/- 2	+/- 2
Output current +/- 5V output +/- 12V output +/- 15V output	Full temperature range Ui min. to max.	Maximum	mA	+/- 400	+/- 400
		Maximum	mA	+/- 165	+/- 165
		Maximum	mA	+/- 130	+/- 130
Ripple output voltage ** 5V output 12V output 15V output	Ui nominal	Maximum	mVpp	50	50
	Full load	Maximum	mVpp	100	100
	BW = 20MHz	Maximum	mVpp	150	150
Line regulation	Ui min. to max. Full load	Typical	%	+/- 1	+/- 1
Load regulation ***	Ui nominal 25% to full load	Typical	%	+/- 2,5	+/- 2,5
Cross load output regulation	Ui nominal + Vout nominal load - Vout from 25% to full load	Typical	%	+/- 0,5	+/- 0,5
Efficiency	Ui nominal Full load	Typical	%	76	78
Maximum admissible Capacitive load 5V output 12V and 15V output	Ui nominal Full load	Maximum	µF	470	470
	Per output		µF	22	22

Note* : The start-up time is the time between start of the module through on/off release, input voltage present, and output voltage settled; for modules without on/off function start up time value is an indicative value and not a maximum value.

Note ** : The ripple output voltage is the periodic AC component imposed on the output voltage, an aperiodic and random component (noise) has also to be considered. This noise can be reduced by adding an external capacitor (typically 10µF/rated voltage depending on isolation requirement) connected between the pin Gin and the pin Gout of the converter. This capacitor should be layed-out as close as possible from the converter.

Note *** : For load regulation characteristics from 0% to full load, please contact factory.

4- Switching Frequency

Parameter	Conditions	Limit or typical	Specifications
Switching frequency	Full temperature range Ui min. to max. No load to full load	Nominal, fixed	4.5-5.5 VDC input : 480 KHz 18-36 VDC input : 480 KHz

5- Isolation

Parameter	Conditions	Limit or typical	Specifications
Electric strength test voltage (basic version)	Input to output	Minimum	1 500 VDC / 1 min
Electric strength test voltage between outputs (for dual and triple outputs)	Output to output	Minimum	No isolation
Isolation resistance	500 VDC	Minimum	100 MOhm

6- Protection Functions

Characteristics	Protection Device	Recovery	Limit or typical	Specifications
Output short circuit protection (SCP)	Hiccup circuitry with auto-recovery	Automatic recovery	Permanent	See section 11
Output overvoltage protection (OVP)	Zener clamp	/	Maximum Maximum Maximum Maximum	For 3.3v : 4v For 5v : 6v For 12v : 14v For 15v : 17v

7- Reliability Data

Characteristics	Conditions	Temperature	Specifications
Mean Time Between Failure (MTBF) According to MIL-HDBK-217F	Ground fixed (Gf)	Case at 40°C Case at 85°C	1 500 000 Hrs 600 000 Hrs
	Ground mobile (Gm)	Case at 40°C Case at 85°C	750 000 Hrs 350 000 Hrs
Mean Time Between Failure (MTBF) According to IEC-62380-TR	Telecom switchers	Ambient at 25°C 100% time on	2 575 000 Hrs

8- Electromagnetic Interference

Electromagnetic interference requirements according to EN55022 class A and class B can be easily achieved as indicated in the following table :

Electromagnetic Interference according to EN55022			
Conducted noise emission	Configuration	With common mode capacitor $C_c = 10\text{nF}$ and input capacitor C_i	With common mode capacitor $C_c = 10\text{nF}$ and external filter
	Models		
	4,5-5,5V input models	Class A, $C_i = 10\mu\text{F} / 35\text{V}$ tantalum	Class B
	18-36V input models	Class A, $C_i = 4.7\mu\text{F} / 50\text{V}$ tantalum	Class B
Radiated noise emission	Configuration	With common mode capacitor $C_c = 10\text{nF}$	
	Models	Class B	
	All models	Class B	

8-1 Module Compliance with EN55022 class A Standard

Electromagnetic interference requirements according to EN55022 class A can be easily achieved by adding an external input capacitance (C_i Value explained in previous table) and a common mode noise capacitance

C_c (10 nF/rated voltage depending on isolation requirement) connected between G_{in} and G_{out} . This common mode noise capacitance C_c should be laid-out as close as possible from the DC/DC converter.

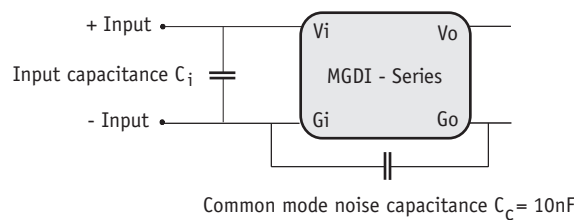

8-2 Module Compliance with EN 55022 Class B Standard

Electromagnetic interference requirements according to EN55022 class B can be easily achieved by adding an external input filter consisting of 4 capacitances, a common mode choke, and a differential mode inductance,

together with a common mode noise capacitance (10 nF/rated voltage depending on isolation requirement) connected between G_{in} and G_{out} . Please consult EN55022 Class B EMI Filter design note for further details.

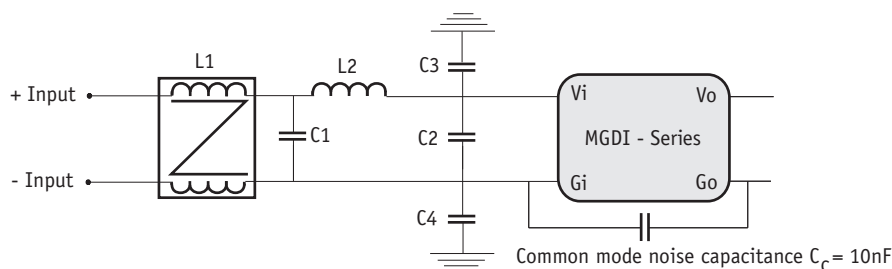

9- Thermal Characteristics

Characteristics	Conditions	Limit or typical	Performances
Operating ambient temperature range at full load	Ambient temperature *	Minimum Maximum	- 40°C + 71°C
Operating case temperature range at full load	Case temperature	Minimum Maximum	- 40°C +95°C
Storage temperature range	Non functioning	Minimum Maximum	- 40°C + 105°C
Thermal resistance	Rth case to ambient in free air natural convection	Typical	20°C /W

Note *: The upper temperature range depends on configuration, the user must assure a max. case temperature of + 95°C.

The MGDI-04 series operating **case** temperature must not exceed 95°C. The maximum **ambient** temperature admissible for the DC/DC converter corresponding to the maximum operating case temperature of 95°C depends on the ambient airflow, the mounting/orientation, the cooling features and the power dissipated.

To calculate a maximum admissible ambient temperature the following method can be used. Knowing the maximum case temperature Tcase = 95°C of the module, the power used Pout and the efficiency η :

- determine the power dissipated by the module P_{diss} that should be evacuated :

$$P_{diss} = P_{out}(1/\eta - 1)$$

- determine the maximum ambient temperature :

$$T_a = 95^\circ\text{C} - R_{th} \times P_{diss}$$

where **Rth** is the thermal resistance from the case to ambient.

The previous thermal calculation shows two areas of operation :

- a normal operation area in a free natural ambient convection (grey area in this following graph),
- an area with cooling features (air flow or heatsink) ensuring a maximum case temperature below the maximum operating case temperature of 95°C (white area in the following graph).

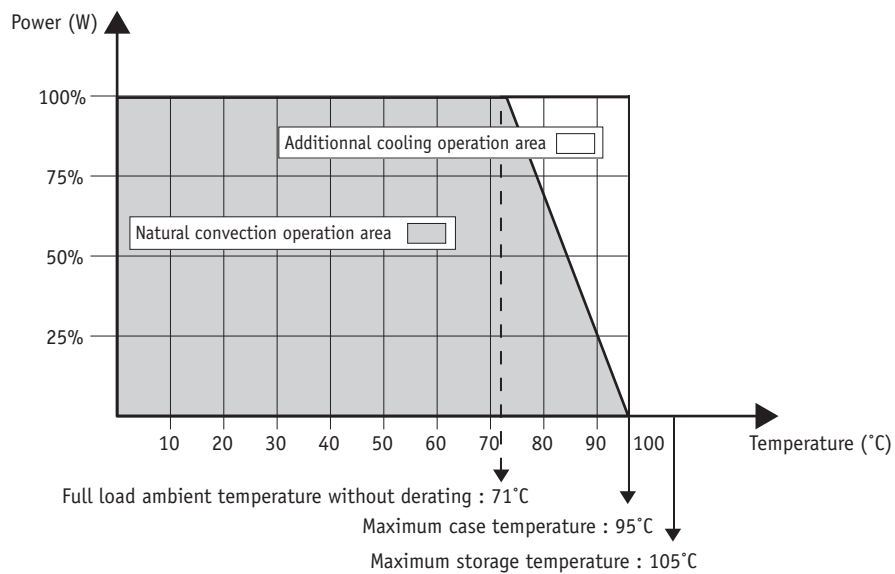

10- Environmental Qualifications

The modules have been subjected to the following environmental qualifications.

Characteristics	Conditions	Severity	Test procedure
Climatic Qualifications			
Life at high temperature	Duration Temperature Status of unit	1 000 Hrs 95°C case unit operating	IEC 68-2-2
Humidity steady	Damp heat Temperature Duration Status of unit	93 % relative humidity 40°C 56 days unit not operating	IEC 68-2-3 Test Ca
Temperature cycling	Number of cycles Temperature change Transfert time Steady state time Status of unit	200 -40°C / +71°C 40 min. 20 min. unit not operating	IEC 68-2-14 Test N
Temperature shock	Number of shocks Temperature change Transfert time Steady state time Status of unit	50 -40°C / +105°C 10 sec. 20 min. unit not operating	IEC 68-2-14 Test Na
Mechanical Qualifications			
Vibration (Sinusoidal)	Number of cycles Frequency : amplitude Frequency : acceleration Amplitude /acceleration Duration Status of unit	10 cycles in each axis 10 to 60 Hz / 0.7 mm 60 to 2000 Hz / 10 g 0.7 mm/10 g 2h 30 min. per axis unit not operating	IEC 68-2-6 Test Fc
Shock (Half sinus)	Number of shocks Peak acceleration Duration Shock form Status of unit	3 shocks in each axis 100 g 6 ms 1/2 sinusoidal unit not operating	IEC 68-2-27 Test Ea
Bump (Half sinus)	Number of bumps Peak acceleration Duration Status of unit	2 000 bumps in each axis 25 g 6 ms unit not operating	IEC 68-2-29 Test Eb
Electrical Immunity Qualifications			
Electrical discharge susceptibility	Number of discharges Air discharge level Contact discharge level Air discharge level Contact discharge level	10 positive & 10 negative discharges 4 kV : sanction A 2 Kk : sanction A 8 Kk : sanction B 4 kV : sanction B	EN55082-2 with : EN61000-4-2 IEC 801-2
Electrical field susceptibility	Antenna position Electromagnetic field Wave form signal Frequency range	at 1 m 10 V/m AM 80%, 1 kHz 26 MHz to 1 GHz	EN55082-2 with : EN61000-4-3 IEC801-3
Electrical fast transient susceptibility	Burst form Wave form signal Impedance Level 1 Level 3	5/50 ns 5 kHz with 15 ms burst duration period 300 ms 50 Ohm 0,5 kV : sanction A 2 kV : sanction B	EN55082-2 with : EN61000-4-4 IEC801-4

11- Description of Protections

11-1 Output Short Circuit Protection (SCP)

The short circuit protection device protects the module against short circuit of any duration and restores the module to normal operation when the short circuit is removed. It operates in «hiccup» mode by testing periodically if an overload is applied (typically every 200ms recovery time). The overload detection threshold is typically 200% of maximum current and typically 300% of maximum current for 'C' input range series with a detection time lower than 5ms.

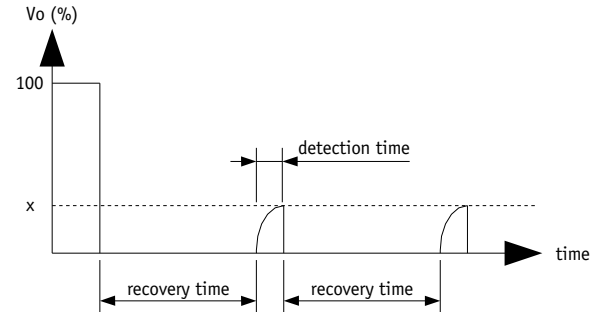

11-2 Output Overvoltage Protection (OVP)

The output overvoltage protection device protects external components against high voltage or possible overvoltages which can be supplied by the module (i.e in case of internal failure). It consists of a zener diode clamping the output voltage; under worst case conditions this zener diode will short-circuit.

The output voltage protection is not designed to withstand externally applied output overvoltages to protect the module itself.

5

12- Description of Functions

12-1 Option (/M) : On/Off Function

The optionnal control pin 20 (On/Off) can be used for applications requiring On/Off operation. By using an open collector command with a transistor Q referenced to the common terminal (Gi) :

- A logic pulled low ($\approx 0.2V@1mA$, referenced to Gi) on pin 20 disables the converter
- No connection or high impedance on pin 20 enables the converter.

By releasing the On/Off function, the converter will restart within the start-up time specifications given in table page 3. For further details please consult "Logic On/Off" application note.

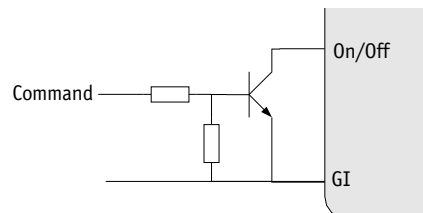

13- Application Notes

13-1 Connection of Outputs in Series

Any of the bi output converters can be configured to produce an output of 10V (+/-5 output models), 24V (+/-12V output models), or 30V (+/-15V output models) by connecting the load across the output (+) and the output (-) with either output grounded, and leaving the common pin floating.

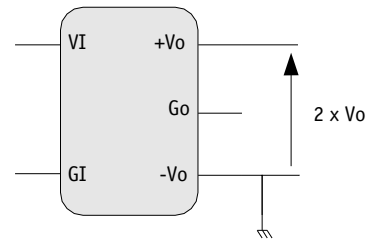

13-2 Connection of Modules in Series

The output of single output units can be connected in series without any precautions to provide higher output voltage level.

Nevertheless, GAIA Converter recommends to protect each individual output by a low power shottky diode rated with the maximum current of the converter to avoid reverse polarity at any output.

Reverse polarity may occur at start up if the output voltages do not rise at the same time.

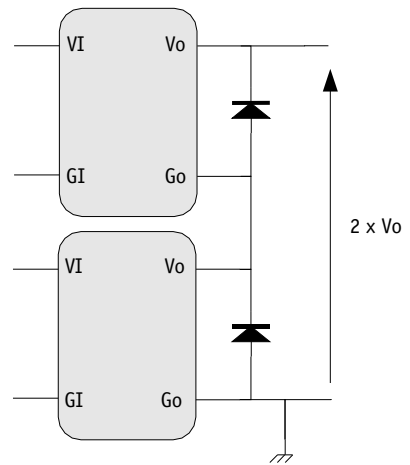

13-3 Connection of Modules in Parallel

Several converters with equal output voltage can be connected in parallel to increase power. Nevertheless some cares have to be taken in particular as the output voltage of each converter is slightly different, when paralleling, the converter with the highest output voltage will source the most current.

However the GAIA Converter modules are designed with a "soft" output voltage versus current characteristic. This causes the output voltage of each converter to automatically adjust downward as its current increases so each converter very approximately shares the total output current. It is important that each converter has approximately the same impedance between their output and the common load.

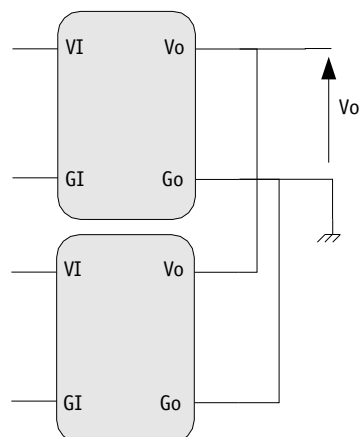

10- Dimensions

Dimensions are given in mm (inches). Tolerance : +/- 0,2 mm (+/- 0,01 ") unless otherwise indicated.
Weight : 10 grams (0.3 Ozs) max.

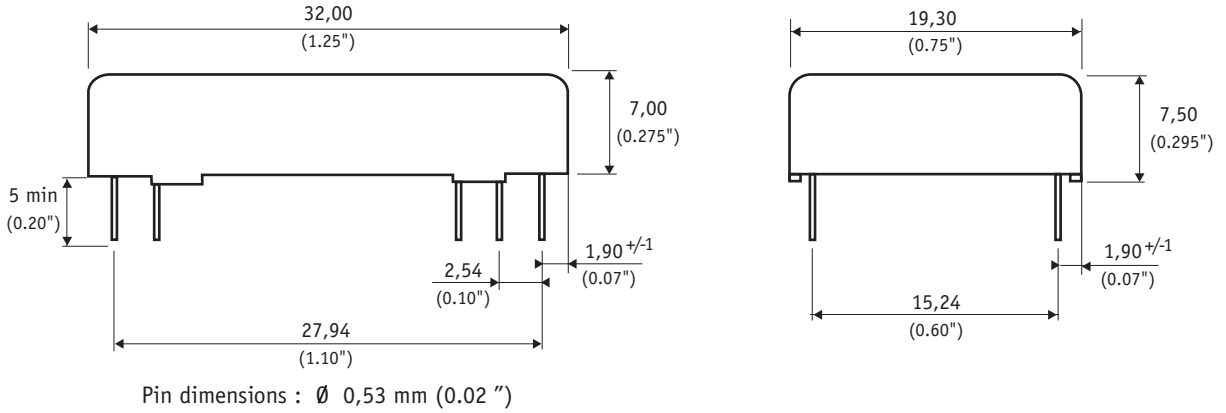

11- Materials

Case : Metallic black anodized coating.
Pins : Plated with pure matte tin over nickel underplate.

12- Product Marking

Upper face : Company logo.
Side face : Module reference, option, date code : year and week of manufacturing.

13- Connections

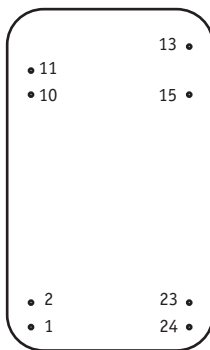

Bi output model

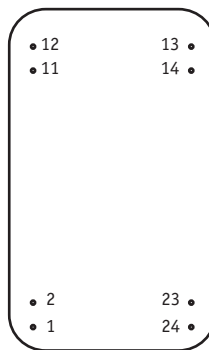

Single output model

Bottom view

Pin	Bi Output	Single Output
1	+ Input (Vi)	+ Input (Vi)
2	+ Input (Vi)	+ Input (Vi)
10	Common (Go)	/
11	Common (Go)	Common (Go)
12	/	Common (Go)
13	Output - (- Vo)	Output (Vo)
14	/	Output (Vo)
15	Output + (+ Vo)	/
20	No pin*	No pin*
23	- Input (Gi)	- Input (Gi)
24	- Input (Gi)	- Input (Gi)

* Option /M : Pin 20 existing for On/Off function.
Please add /M to module reference.



Represented by :