



# CQB150-300S-CMFC(D) SERIES 50-75 WATT 2:1 INPUT ISOLATED DC-DC CONVERTERS

## Features

- Efficiency Up to 89%
- Fixed Switching Frequency
- Regulated Outputs
- Remote On/Off
- Low No Load Power Consumption
- Fully protected (OTP/OCP/OVP/UVLO)
- 3000Vac I/O Isolation
- Operating Case Temperature -40 to +100°C
- UL62368-1 (Reinforce Insulation) Approval for DC Modules
- EN55032/22 for EMC Characteristic
- Shock & Vibration Mil-STD-810F Compliant
- Fire & Smoke EN45545-2 Compliant
- Safety Meets IEC/EN/UL 62368-1
- Build-In EMI Filter
- Chassis Mount, Baseplate Cooled



MODEL NUMBER	INPUT VOLTAGE	OUTPUT VOLTAGE	OUTPUT CURRENT		INPUT CURRENT		% EFF.	CAPACITOR LOAD MAX.
			MIN.	MAX.	NO LOAD	FULL LOAD		
CQB150-300S05□-CMFC CQB150-300S05□-CMFD	180-425 VDC	5 VDC	0 mA	30 A	10 mA	580 mA	85.5	10000uF
CQB150-300S12□-CMFC CQB150-300S12□-CMFD	180-425 VDC	12 VDC	0 mA	12.5 A	10 mA	560 mA	89	8800uF
CQB150-300S15□-CMFC CQB150-300S15□-CMFD	180-425 VDC	15 VDC	0 mA	10 A	10 mA	560 mA	89	8800uF
CQB150-300S24□-CMFC CQB150-300S24□-CMFD	180-425 VDC	24 VDC	0 mA	6.3 A	10 mA	570 mA	88.5	3300uF
CQB150-300S28□-CMFC CQB150-300S28□-CMFD	180-425 VDC	28 VDC	0 mA	5.4 A	10 mA	570 mA	88.5	3300μF
CQB150-300S48□-CMFC CQB150-300S48□-CMFD	180-425 VDC	48 VDC	0 mA	3.2 A	10 mA	570 mA	89	1000μF

**NOTE:**

1. Nominal Input Voltage 300 VDC
2. □ = N or none
3. VR is Used for Output Voltage Adjustment.
4. Refer to Application Note for Thermal Resistance and Derating Information.
5. TVS is Included for Input Surge Voltage Protection.
6. Recommend an External Fuse for Input Reverse Polarity Protection (shunt diode is included inside).
7. Output connector CN3 wafer with TAIWAN KING PIN TERMINAL P110I series and mate with JST housing PH series or equivalent.
8. CN1 connection: DINKLE 166-04P5 series or equivalent, suitable electric wire: 18~12AWG (IEC 0.5~4mm<sup>2</sup>).
9. CN2 connection: DINKLE EK500V-04P series or equivalent, suitable electric wire: 24~12AWG (IEC 0.5~2.5mm<sup>2</sup>).

## PART NUMBER

Series	Nominal Input Voltage	Number of Outputs	Nominal Output Voltage	Remote On/Off Logic	Chassis Mount Type		Heatsink
					-YYY	Z	
CQB150	II	O	XX	L			+WW
CQB150	300 : 300 VDC	S : Single	05 : 5VDC 12 : 12VDC 15 : 15VDC 24 : 24VDC 28 : 28VDC 48 : 48VDC	None : Positive N : Negative	Chassis CMF : Mount Built in Filter	C : Open Frame  D : With Cover	None : Blank  HS : Heatsink HD : Heatsink+Din Rail

Part Number Example:

**CQB150-300S12N-CMFC:** Chassis Mount, 150W, 2:1 180-425Vdc Input, Single 12Vdc Output, Negative Logic, Open Frame



# CQB150-300S CMFC(D) Series

## TECHNICAL SPECIFICATIONS

(All specifications are typical at nominal input, full load at 25°C unless otherwise noted.)

### ABSOLUTE MAXIMUM RATINGS

PARAMETER	NOTES and CONDITIONS	Device	Min.	Typ.	Max.	Units
Input Voltage	Continuous	All	-0.3		425	V <sub>dc</sub>
Input Surge Voltage	100ms max.	All			500	V <sub>dc</sub>
Operating Case Temperature	At the center part of base plate	All	-40		100	°C
Storage Temperature		All	-40		105	°C

### INPUT CHARACTERISTICS

PARAMETER	NOTES and CONDITIONS	Device	Min.	Typ.	Max.	Units	
Operating Input Voltage		All	180	300	425	V <sub>dc</sub>	
Input Under Voltage Lockout							
Turn-On Voltage Threshold	Full load	All	165	170	175	V <sub>dc</sub>	
Turn-Off Voltage Threshold	Full load	All	155	160	165	V <sub>dc</sub>	
Lockout Hysteresis Voltage	Full load	All		10		V <sub>dc</sub>	
Input Over Voltage Protection	Module on	All		440		V <sub>dc</sub>	
	Module off	All		450			
Maximum Input Current	V <sub>in</sub> =180V, Full load	All		1		A	
No-Load Input Current	V <sub>in</sub> =300V, I <sub>o</sub> =0A	See Model Number Table					mA

### OUTPUT CHARACTERISTICS

PARAMETER	NOTES and CONDITIONS	Device	Min.	Typ.	Max.	Units
Voltage Set Point Accuracy	V <sub>in</sub> =300V, Full load, T <sub>c</sub> =25°C	All	-1.0		+1.0	%
Output Voltage Regulation						
Load Regulation	Full load to no load	05Vo			±0.5	%
		Others			±0.2	
Line Regulation	V <sub>in</sub> =High line to low line, full load	All			±0.2	%
Temperature Coefficient	T <sub>c</sub> =-40°C to 105°C	All			±0.02	%/°C
Output Voltage Ripple and Noise (5Hz to 20MHz Bandwidth)						
Peak-to-Peak	Full load, 1uF ceramic capacitors	5Vo			120	mV
		12Vo			150	
		15Vo			150	
		24Vo			200	
		28Vo			200	
		48Vo			300	
RMS.	Full load, 1uF ceramic capacitors	5Vo			60	mV
		12Vo			80	
		15Vo			80	
		24Vo			100	
		28Vo			100	
		48Vo			150	
Output Current Range	V <sub>in</sub> = 180 to 425V	See Model Number Table				A
Over Current Protection	Hiccup mode. Auto recovery	All	110	125	160	%
Short Circuit Protection		All	Continuous, Auto Recovery			
External Load Capacitance	Full load (resistive)	See Model Number Table				uF
Output Voltage Trim Range	P <sub>o</sub> ≤ max. rated power, I <sub>o</sub> ≤ I <sub>o_max</sub> .	All	-20		+10	%
Output Voltage Remote Sense Range	P <sub>o</sub> ≤ max. rated power, I <sub>o</sub> ≤ I <sub>o_max</sub> . % of Nominal Vo	All			+10	%
Over Voltage Protection	Limited voltage, % of nominal V <sub>o</sub>	All	115	125	140	%



# CQB150-300S CMFC(D) Series

## EFFICIENCY

PARAMETER	NOTES and CONDITIONS	Device	Min.	Typ.	Max.	Units
100% Load	$V_{in}=300V$	See Model Number Table				%

## DYNAMIC CHARACTERISTICS

PARAMETER	NOTES and CONDITIONS	Device	Min.	Typ.	Max.	Units
Output Voltage Current Transient						
Error Band	75% to 100% of $I_{o\_max}$ . Step load change $di/dt=0.1A/us$ (within 1% $V_{out}$ nominal)	All			±5	%
Recovery Time		All			250	us
Turn-On Delay and Rise Time						
Full load (constant resistive load)						
Turn-On Delay Time, From On/Off Control	$V_{on/off}$ to 10% $V_{o\_set}$ , Remote on	All		300		ms
Turn-On Delay Time, From Input	$V_{in\_min.}$ to 10% $V_{o\_set}$ , Power up	All		300		ms
Output Voltage Rise Time	10% $V_{o\_set}$ to 90% $V_{o\_set}$	All		50		ms

## ISOLATION CHARACTERISTICS

PARAMETER	NOTES and CONDITIONS	Device	Min.	Typ.	Max.	Units
Isolation Voltage (100% factory Hi-Pot tested @2sec.)	1 Minute; input to output	All			3000 4200	$V_{ac}$ $V_{dc}$
	1 Minute; input to case (base plate)	All			2500 3500	$V_{ac}$ $V_{dc}$
	1 Minute; output to case (base plate)	All			500 700	$V_{ac}$ $V_{dc}$
Isolation Resistance	Input to output	All	100			MΩ
Isolation Capacitance	Input to output	All		NC		pF
	Input to case (base plate)	5Vo 12Vo 15Vo 24Vo 28Vo 48Vo		3440		
		Output to case (base plate)	All		28200	

## FEATURE CHARACTERISTICS

PARAMETER	NOTES and CONDITIONS	Device	Min.	Typ.	Max.	Units
Switching Frequency	Pulse width modulation (PWM), fixed	All	270	300	330	KHz
On/Off Control, Positive Remote On/Off Logic, Refer to -Vin Pin.						
Logic Low (Module Off)	$V_{on/off}$ at $I_{on/off}=0.0uA$ , Pin open=off	All	0		1.2	V
Logic High (Module On)	$V_{on/off}$ at $I_{on/off}=1.0mA$	All	3.5		12	V
On/Off Control, Negative Remote On/Off Logic, Refer to -Vin Pin						
Logic High (Module Off)	$V_{on/off}$ at $I_{on/off}=1.0mA$	All	3.5		12	V
Logic Low (Module On)	$V_{on/off}$ at $I_{on/off}=0.0uA$ , Pin open=on	All	0		1.2	V
On/Off Current (for both remote on/off logic)	$I_{on/off}$ at $V_{on/off}=3.5-12V$	All	0.3		2.1	mA
Off Converter Input Current	Shutdown input idle current	All		3	5	mA
Over Temperature Shutdown	Temperature at the center part of base plate, non-latching	All		105		°C
Over Temperature Recovery		All		95		°C



# CQB150-300S CMFC(D) Series

## GENERAL SPECIFICATIONS

PARAMETER	NOTES and CONDITIONS	Device	Min.	Typ.	Max.	Units
MTBF	I <sub>o</sub> =100% of I <sub>o_max</sub> ; MIL-HDBK - 217F_Notice 1, GB, 25°C	5Vo		509		K hours
		12Vo		557		
		15Vo		589		
		24Vo		598		
		28Vo		543		
		48Vo		639		
Weight		-CMFC		197		grams
		-CMFD		225		
		-CMFD+HS		472		
		-CMFD+HD		490		
Base plate Material	Aluminum					
Potting Material	UL 94V-0 (DC Module)					
Shock/Vibration	MIL-STD-810F Compliant					
Humidity	95% RH max. Non Condensing					
Altitude	2000m Operating Altitude, 12000m Transport Altitude					
Thermal Shock	MIL-STD-810F					
Fire & Smoke	EN45545-2 Compliant					
EMI	EN55032 & EN55022 Compliant					Class A
ESD	EN61000-4-2 Level 3: Air ±8kV, Contact ±6kV					Perf. Criteria A
Radiated immunity	EN61000-4-3 Level 3: 80~1000MHz, 20V/m					Perf. Criteria A
Fast Transient	EN61000-4-4 Level 3: On power input port, ±2kV					Perf. Criteria A
Surge	EN61000-4-5 Level 4: Line to earth, ±4kV, Line to line, ±2kV					Perf. Criteria A
Conducted immunity	EN61000-4-6 Level 3: 0.15~80MHz, 10V					Perf. Criteria A
Power Frequency Magnetic Field immunity	EN61000-4-8 50/60Hz, 3A/m (r.m.s.)					Perf. Criteria A
Application Note Link	<a href="#">CQB150-300S CMFC(D) Series App Notes</a>					
Packaging Information Link	<a href="#">Packaging Information</a>					

## Immunity to Environmental Conditions.

Phenomenon	Reference Clause(s)	Reference Standard	Test Conditions	Result
Vibration Test	MIL-STD-810F Table 514.5C-VIII Figure 514.5C-6	MIL-STD-810F	Unit are non-operating Vibration Waveform: Random Vibration Frequency: 15 ~ 2000 Hz Vibration axis: X · Y · Z axis Duration: 1hr/axis	Vibration Test
Shock Test	MIL-STD-810F 516.5 Table 516.5-I	MIL-STD-810F	Wave form: Sawtooth wave Test Category: Crash Hazard Test for Ground Equipment Duration: 10 ms Peak Acceleration: 75 G Cross-over Frequency: 80 Hz No. of Shock: Each axis 3 times Shock Direction: ±X, ±Y, ±Z axis	Shock Test
Thermal Shock Cycling Test	MIL-STD-810F 503.4 Figure 503.4-1	MIL-STD-810F	Temperature : -55°C to 105°C Humidity: 95%RH Duration: 8hrs/ 3 times cycling& 4hrs dwell time	Thermal Shock Cycling Test
Thermal Humidity Cycling Test	MIL-STD-810F Notice 3 Method 507.4	MIL-STD-810F	Temperature: 60°C to 30°C Humidity: 95%RH Duration: 240 hrs	Thermal Humidity Cycling Test



# CQB150-300S CMFC(D) Series

## EN45545-2 Fire & Smoke Test Conditions.

Item		Standard	Hazard Level
R22	Oxygen Index Test	EN 45545-2: 2013 EN ISO 4589-2: 2006	HL1, HL2, HL3
	Smoke Density Test	EN 45545-2: 2013 EN ISO 5659-2: 2013	HL1, HL2, HL3
	Smoke Toxicity Test	EN 45545-2: 2013 NF X70-100: 2006	HL1, HL2, HL3
R23	Oxygen Index Test	EN 45545-2: 2013 EN ISO 4589-2: 2006	HL1, HL2, HL3
	Smoke Density Test	EN 45545-2: 2013 EN ISO 5659-2: 2013	HL1, HL2, HL3
	Smoke Toxicity Test	EN 45545-2: 2013 NF X70-100: 2006	HL1, HL2, HL3
R24	Oxygen Index Test	EN45545-2: 2013 EN ISO 4589-2	HL1, HL2, HL3
R25	Glow - Wire Test	EN 45545-2:2013 EN 60695-2-11:2001	HL1, HL2, HL3
R26	Vertical Flame Test	EN 45545-2: 2013 EN 60695-11-10: 2013	HL1, HL2, HL3

## CHARACTERISTIC CURVE

### Power Derating Curve

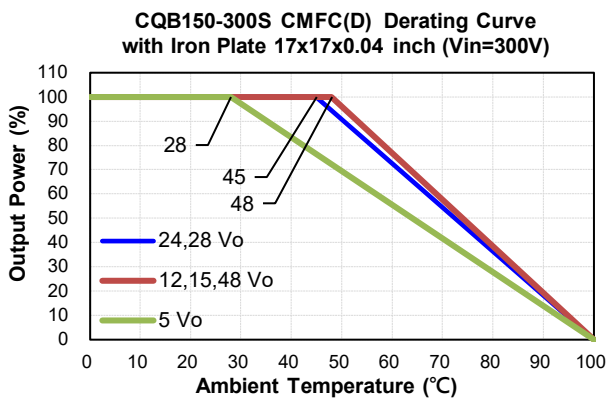
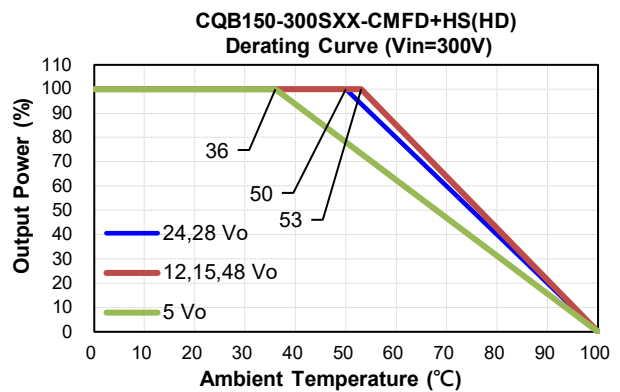
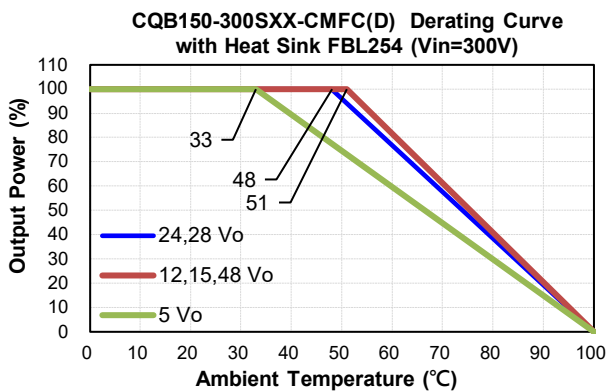



# CQB150-300S CMFC(D) Series

## Performance Data

**CQB150-300S05-CMFC**  
Eff Vs Io @25 Deg. C

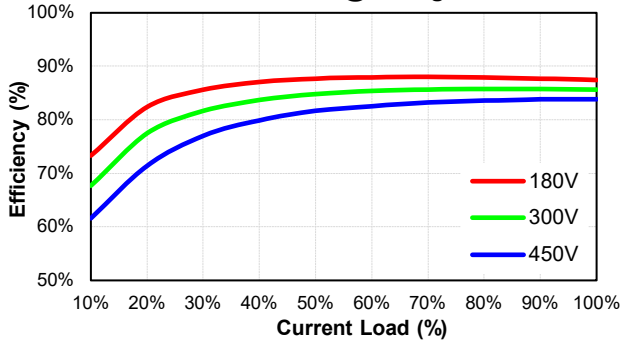

**CQB150-300S05-CMFC**  
Pd Vs Po @25 Deg. C

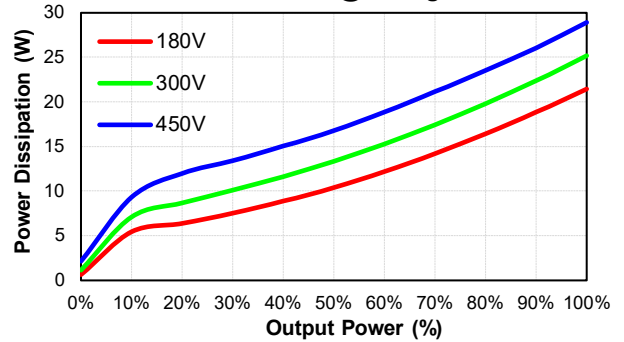

**CQB150-300S12-CMFC**  
Eff Vs Io @25 Deg. C

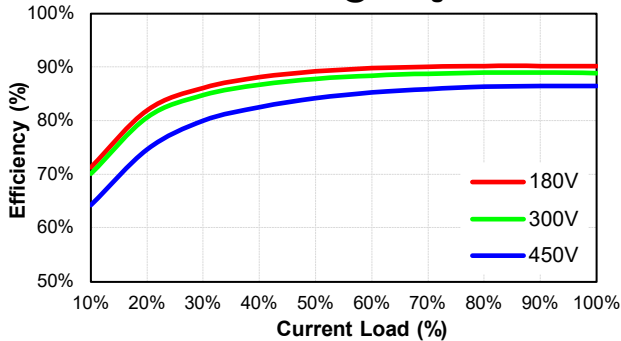

**CQB150-300S12-CMFC**  
Pd Vs Po @25 Deg. C

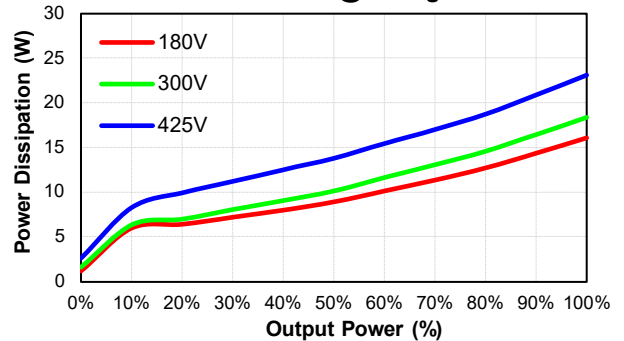

**CQB150-300S15-CMFC**  
Eff Vs Io @25 Deg. C

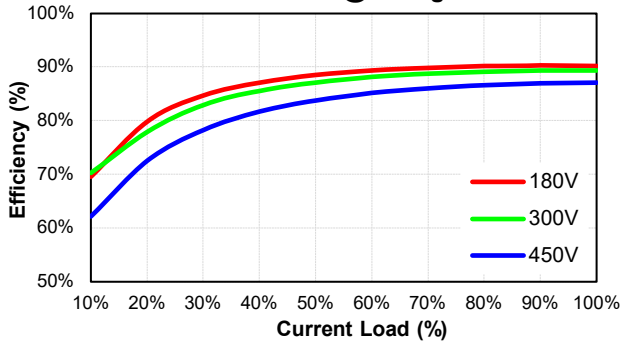

**CQB150-300S15-CMFC**  
Pd Vs Po @25 Deg. C

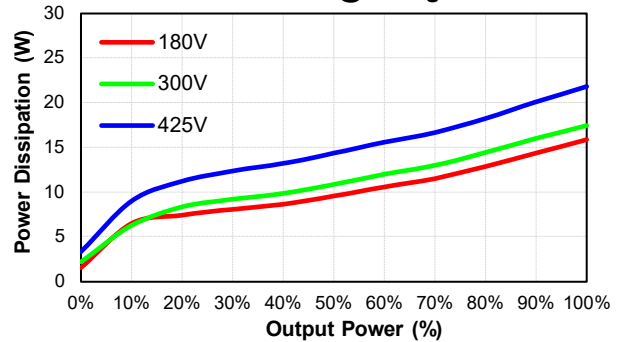

**CQB150-300S24-CMFC**  
Eff Vs Io @25 Deg. C

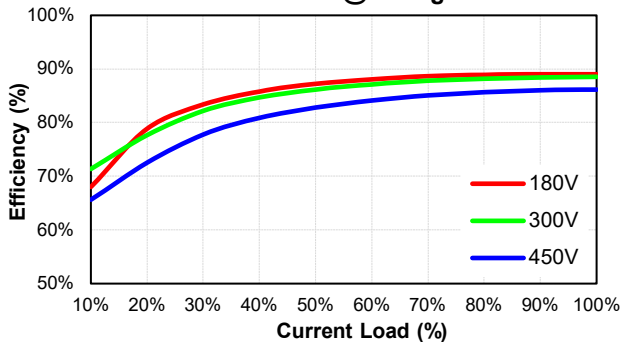

**CQB150-300S24-CMFC**  
Pd Vs Po @25 Deg. C

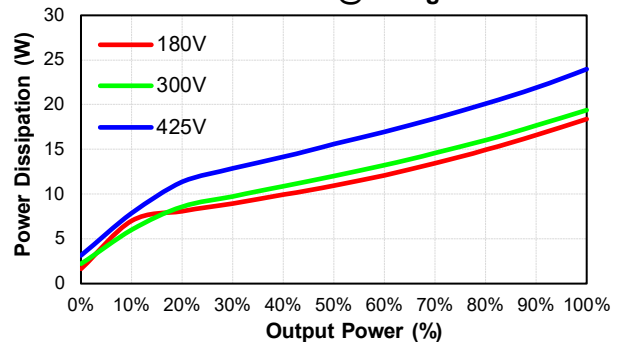



# CQB150-300S CMFC(D) Series

**CQB150-300S28-CMFC**  
Eff Vs Io @25 Deg. C

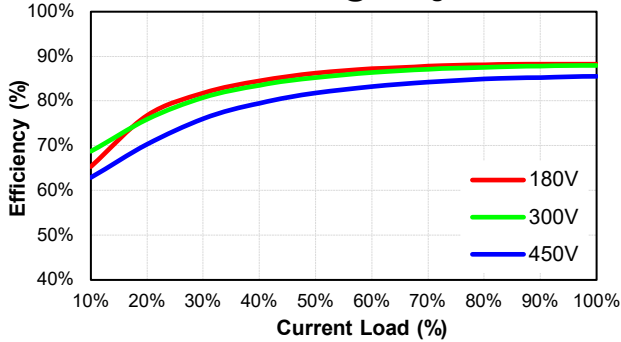

**CQB150-300S28-CMFC**  
Pd Vs Po @25 Deg. C

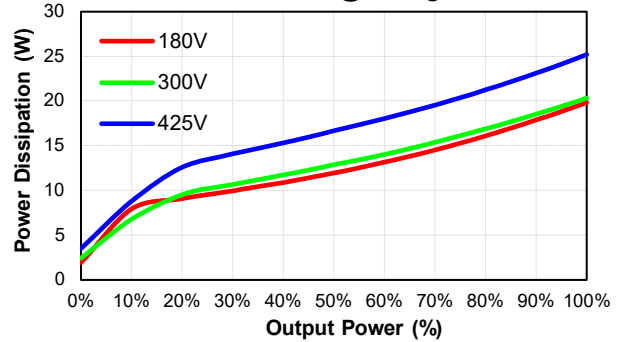

**CQB150-300S48-CMFC**  
Eff Vs Io @25 Deg. C

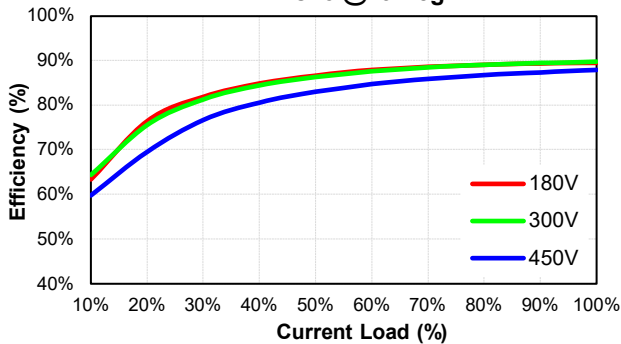

**CQB150-300S48-CMFC**  
Pd Vs Po @25 Deg. C

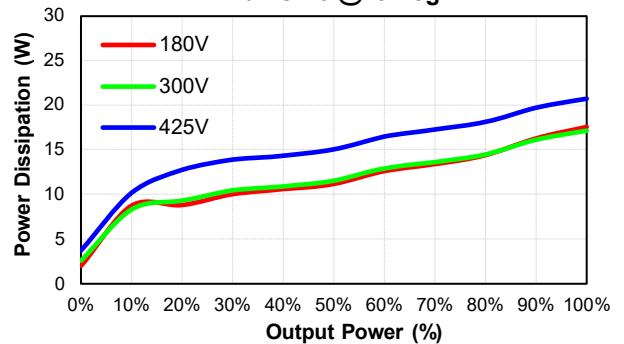



# CQB150-300S CMFC(D) Series

## MECHANICAL SPECIFICATION

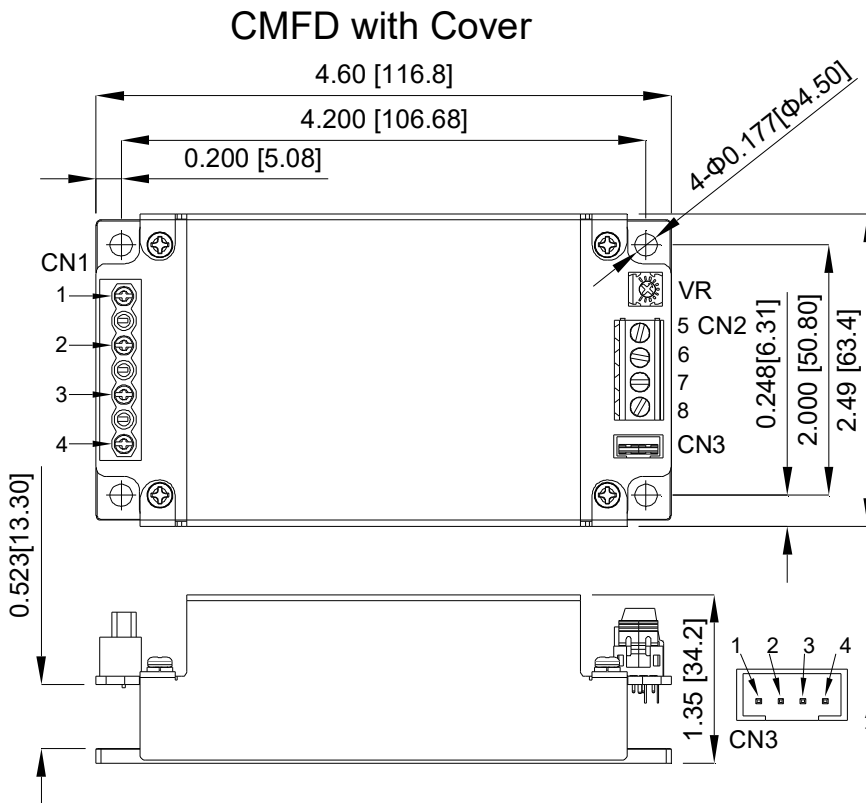
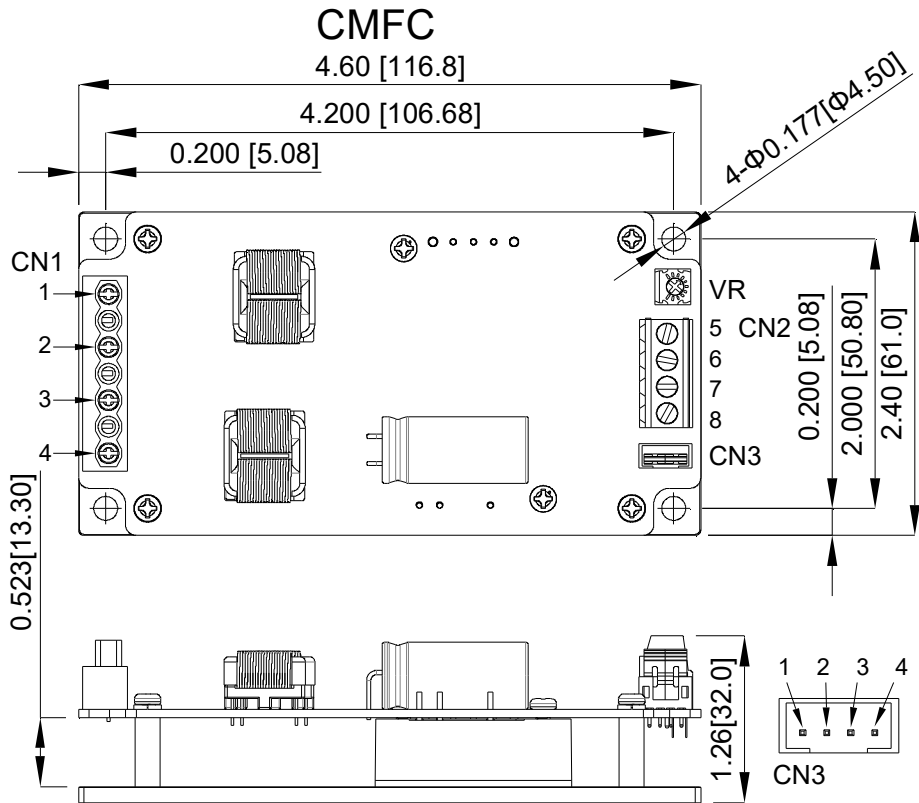

**CN1 & CN2  
PIN CONNECTION**

PIN	Function
1	+V Input
2	-V Input
3	Remote
4	Case
5	+V Output
6	+V Output
7	-V Output
8	-V Output

**CN3  
PIN CONNECTION**

PIN	Function
1	-V Output
2	-Sense
3	+Sense
4	+V Output

All Dimensions in Inches[mm]  
Tolerance Inches: x.xx=±0.02, x.xxx=±0.010  
Millimeters: x.x=±0.5, x.xx=±0.25





# CQB150-300S CMFC(D) Series

## MECHANICAL SPECIFICATION

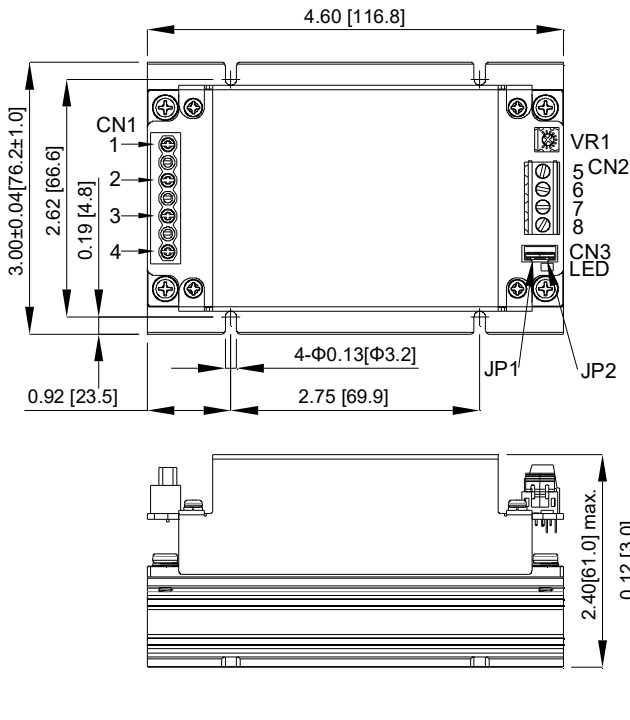

### CMFD+HS

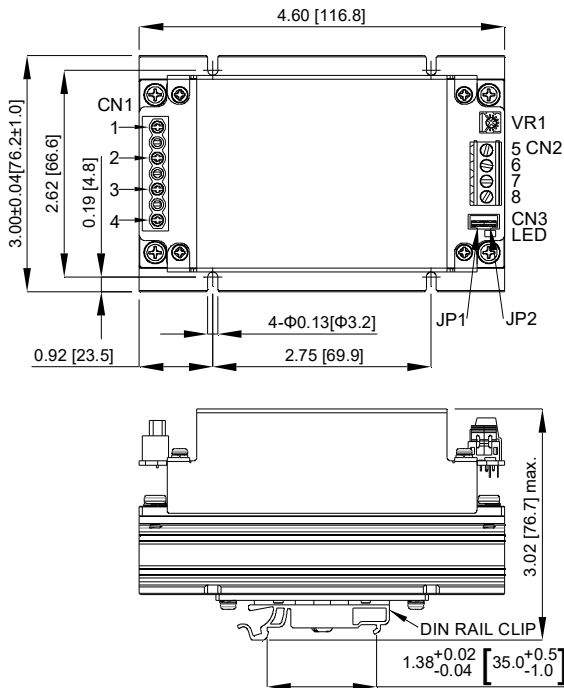
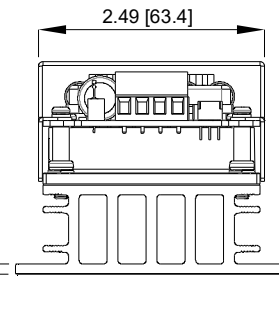
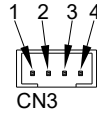

### CMFD+HD

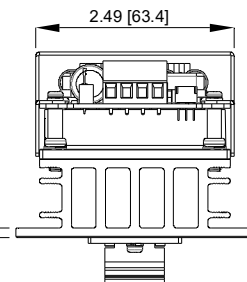
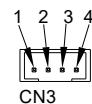

#### CN1 & CN2 PIN CONNECTION

PIN	Function
1	+V Input
2	-V Input
3	Remote
4	Case
5	+V Output
6	+V Output
7	-V Output
8	-V Output

#### CN3 PIN CONNECTION

PIN	Function
1	-V Output
2	-Sense
3	+Sense
4	+V Output

\*JP1: Short PIN1 & PIN2  
\*JP2: Short PIN3 & PIN4

All Dimensions in Inches [mm]  
Tolerance Inches: x.xx=±0.02, x.xxx=±0.010  
Millimeters: x.x=±0.5, x.xx=±0.25