



CQB50W12-CMFC(D) SERIES 30-50 WATT 12:1 INPUT ISOLATED DC-DC CONVERTERS

Features

- Efficiency Up to 89%
- Fixed Switching Frequency
- Regulated Outputs
- Remote On/Off
- Low No Load Power Consumption
- Fully protected (OTP/OCP/OVP/UVLO)
- 3000Vdc I/O Isolation
- Operating Case Temperature -40 to +100°C
- UL60950-1 2nd (Basic Insulation) Approval for DC Modules
- EN50155 for EMC, Environmental and Characteristic
- Shock & Vibration EN50155 (EN61373) Compliant
- Fire & Smoke EN45545-2 Compliant
- Safety Meets IEC/EN/UL 60950-1
- Build-In EMI Filter
- Chassis Mount, Baseplate Cooled



| MODEL NUMBER | INPUT VOLTAGE | OUTPUT VOLTAGE | OUTPUT CURRENT | | INPUT CURRENT | | % EFF. | CAPACITOR LOAD MAX. |
|--|---------------|----------------|----------------|--------|---------------|-----------|--------|---------------------|
| | | | MIN. | MAX. | NO LOAD | FULL LOAD | | |
| CQB50W12-72S05□-CMFC CQB50W12-72S05□-CMFD | 14-160 VDC | 5 VDC | 0 mA | 6.0 A | 8 mA | 530 mA | 83 | 10000uF |
| CQB50W12-72S12□-CMFC CQB50W12-72S12□-CMFD | 14-160 VDC | 12 VDC | 0 mA | 4.2 A | 8 mA | 810 mA | 87 | 6800uF |
| CQB50W12-72S24□-CMFC CQB50W12-72S24□-CMFD | 14-160 VDC | 24 VDC | 0 mA | 2.1 A | 8 mA | 810 mA | 89 | 3300μF |
| CQB50W12-72S48□-CMFC CQB50W12-72S48□-CMFD | 14-160 VDC | 48 VDC | 0 mA | 1.05 A | 12 mA | 810 mA | 88 | 680μF |

NOTE:

1. Nominal Input Voltage 72 VDC, Input Voltage Range: 14-16.8 VDC (t ≤ 60 sec.)
2. □ = N or none
3. VR1 is Used for Output Voltage Adjustment.
4. Refer to Application Note for Thermal Resistance and Derating Information.
5. TVS is Included for Input Surge Voltage Protection.
6. Recommend an External Fuse for Input Reverse Polarity Protection (shunt diode is included inside).
7. Output connector CN3 wafer with TAIWAN KING PIN TERMINAL P110I series and mate with JST housing PH series or equivalent.
8. CN1 & CN2 connection: DINKLE EK500V-04P series or equivalent, suitable electric wire: 24~12AWG (IEC 0.5~2.5mm²).

PART NUMBER

| Series | Nominal Input Voltage | Number of Outputs | Nominal Output Voltage | Remote On/Off Logic | Chassis Mount Type | | Heatsink |
|-----------|-----------------------|-------------------|---|---------------------------------|-------------------------------------|----------------------------------|--|
| CQB50W12- | II | O | XX | L | -YYY | Z | +WW |
| CQB50W12 | 72 : 72 VDC | S : Single | 05 : 5VDC 12 : 12VDC 24 : 24VDC 48 : 48VDC | None : Positive N : Negative | CMF : Chassis Mount Built in Filter | C : Open Frame D : With Cover | None : Blank HS : Heatsink HD : Heatsink+ Din Rail |

Part Number Example:

CQB50W12-72S12N-CMFC: Chassis Mount, 50W, 12:1 14-160Vdc Input, Single 12Vdc Output, Negative Logic, Open Frame



CQB50W12 CMFC(D) Series

TECHNICAL SPECIFICATIONS

(All specifications are typical at nominal input, full load at 25°C unless otherwise noted.)

ABSOLUTE MAXIMUM RATINGS

| PARAMETER | NOTES and CONDITIONS | Device | Min. | Typ. | Max. | Units |
|----------------------------|----------------------------------|--------|------|------|------|-----------------|
| Input Voltage | Continuous | All | -0.3 | | 160 | V _{dc} |
| Input Surge Voltage | 100ms max. | All | | | 200 | V _{dc} |
| Operating Case Temperature | At the center part of base plate | All | -40 | | 100 | °C |
| Storage Temperature | | All | -40 | | 105 | °C |

INPUT CHARACTERISTICS

| PARAMETER | NOTES and CONDITIONS | Device | Min. | Typ. | Max. | Units |
|-----------------------------|--|----------------|------------------------|----------|------|-----------------|
| Operating Input Voltage | | All | 14 | 72 | 160 | V _{dc} |
| Input Under Voltage Lockout | | | | | | |
| Turn-On Voltage Threshold | Full load | All | 14.2 | 14.6 | 15 | V _{dc} |
| Turn-Off Voltage Threshold | Full load | All | 11.6 | 12.6 | 13 | V _{dc} |
| Lockout Hysteresis Voltage | Full load | All | | 2.0 | | V _{dc} |
| Maximum Input Current | V _{in} =16.8V, Full load | 72S05 Other | | 2.3 4 | | A |
| No-Load Input Current | V _{in} =72V, I _o =0A | | See Model Number Table | | | mA |

OUTPUT CHARACTERISTICS

| PARAMETER | NOTES and CONDITIONS | Device | Min. | Typ. | Max. | Units |
|--|--|--------|----------------------------|------|-------|-------|
| Voltage Set Point Accuracy | V _{in} =72V, Full load, T _c =25°C | All | -1.0 | | +1.0 | % |
| Output Voltage Regulation | | | | | | |
| Load Regulation | Full load to no load | All | | | ±0.2 | % |
| Line Regulation | V _{in} =High line to low line, full load | All | | | ±0.2 | % |
| Temperature Coefficient | T _c =-40°C to 100°C | All | | | ±0.02 | %/°C |
| Output Voltage Ripple and Noise (5Hz to 20MHz bandwidth) | | | | | | |
| Peak-to-Peak | Full load, 1uF ceramic capacitors | All | | | 100 | mV |
| RMS. | | | | | 40 | |
| Output Current Range | V _{in} = 14 to 160V | | See Model Number Table | | | A |
| Over Current Protection | Hiccup mode. Auto recovery | All | 110 | 180 | 220 | % |
| Short Circuit Protection | | All | Continuous, Auto Recovery. | | | |
| External Load Capacitance | Full load (resistive) | | See Model Number Table | | | uF |
| Output Voltage Trim Range | P _o ≤ max rated power, I _o ≤ I _{o_max} | All | -20 | | +10 | % |
| Output Voltage Remote Sense Range | P _o ≤ max rated power, I _o ≤ I _{o_max} % of nominal V _o | All | | | +10 | % |
| Over Voltage Protection | Limited voltage, % of nominal V _o | All | 115 | 125 | 140 | % |

EFFICIENCY

| PARAMETER | NOTES and CONDITIONS | Device | Min. | Typ. | Max. | Units |
|-----------|----------------------------|--------|------------------------|------|------|-------|
| 100% Load | V _{in} =72V, 110V | | See Model Number Table | | | % |

DYNAMIC CHARACTERISTICS

| PARAMETER | NOTES and CONDITIONS | Device | Min. | Typ. | Max. | Units |
|----------------------------------|---|--------|------|------|------|-------|
| Output Voltage Current Transient | | | | | | |
| Error Band | 75% to 100% of I _{o_max} step load change d/d _t =0.1A/us (within 1% V _{out} nominal) | All | | | ±5 | % |
| Recovery Time | | | | | 250 | us |



CQB50W12 CMFC(D) Series

| PARAMETER | NOTES and CONDITIONS | Device | Min. | Typ. | Max. | Units |
|---|--|--------|------|------|------|-------|
| Turn-On Delay and Rise Time | Full load (Constant resistive load) | | | | | |
| Turn-On Delay Time, From On/Off Control | $V_{on/off}$ to 10% V_{o_set} , Remote on | All | | 15 | | ms |
| Turn-On Delay Time, From Input | V_{in_min} to 10% V_{o_set} , Power up | All | | 15 | | ms |
| Output Voltage Rise Time | 10% V_{o_set} to 90% V_{o_set} | All | | 10 | | ms |

ISOLATION CHARACTERISTICS

| PARAMETER | NOTES and CONDITIONS | Device | Min. | Typ. | Max. | Units |
|--|---------------------------------------|--------|------|-------|------|----------|
| Isolation Voltage (100% factory Hi-Pot tested @2sec.) | 1 Minute; input to output | All | | | 3000 | V_{dc} |
| | 1 Minute; input to case (base plate) | | | | 2500 | |
| | 1 Minute; output to case (base plate) | | | | 500 | V_{ac} |
| Isolation Resistance | Input to output | All | 200 | | | MΩ |
| Isolation Capacitance | Input to output | All | | 3000 | | pF |
| | Input to case (base plate) | | | 5000 | | |
| | Output to case (base plate) | | | 10000 | | |

FEATURE CHARACTERISTICS

| PARAMETER | NOTES and CONDITIONS | Device | Min. | Typ. | Max. | Units |
|--|--|--------|------|------|------|-------|
| Switching Frequency | Pulse width modulation (PWM), fixed | All | 215 | 240 | 265 | KHz |
| On/Off Control, Positive Remote On/Off logic, Refer to -Vin pin. | | | | | | |
| Logic Low (Module Off) | $V_{on/off}$ at $I_{on/off}=1.0mA$ | All | 0 | | 1.2 | V |
| Logic High (Module On) | $V_{on/off}$ at $I_{on/off}=0.0uA$, Pin open=on | | 3.5 | | 160 | |
| On/Off Control, Negative Remote On/Off logic, Refer to -Vin pin | | | | | | |
| Logic High (Module Off) | $V_{on/off}$ at $I_{on/off}=0.0uA$, Pin open=off | All | 4.0 | | 160 | V |
| Logic Low (Module On) | $V_{on/off}$ at $I_{on/off}=1.0mA$ | | 0 | | 1.2 | |
| On/Off Current (for both remote on/off logic) | $I_{on/off}$ at $V_{on/off}=0V$ | All | | 0.3 | 1 | mA |
| Leakage Current (for both remote on/off logic) | Logic high, $V_{on/off}=15V$ | All | | | 30 | uA |
| Off Converter Input Current | Shutdown input idle current | All | | 3 | 5 | mA |
| Over Temperature Shutdown | Temperature at the center part of base plate, non-latching | All | | 110 | | °C |
| Over Temperature Recovery | | | | 100 | | |

GENERAL SPECIFICATIONS

| PARAMETER | NOTES and CONDITIONS | Device | Min. | Typ. | Max. | Units |
|---------------------|---|----------|------|------|------|------------------|
| MTBF | $I_o=100\%$ of I_{o_max} ; MIL-HDBK - 217F_Notice 1, GB, 25°C | 72S05 | | 506 | | K hours |
| | | 36S12 | | 484 | | |
| | | 36S24 | | 515 | | |
| | | 36S48 | | 513 | | |
| Weight | | -CMFC | | 215 | | grams |
| | | -CMFD | | 250 | | |
| | | -CMFD+HS | | 470 | | |
| | | -CMFD+HD | | 490 | | |
| Base plate Material | Aluminum | | | | | |
| Potting Material | UL 94V-0 (DC Module) | | | | | |
| Shock/Vibration | EN50155 (EN61373) Compliant | | | | | |
| Humidity | 95% RH max. Non Condensing | | | | | |
| Altitude | 5000m Operating Altitude, 12000m Transport Altitude | | | | | |
| Thermal Shock | MIL-STD-810F | | | | | |
| Fire & Smoke | EN45545-2 Compliant | | | | | |
| EMI | EN55032 & EN50155 Compliant (with external output filter) | | | | | Class A |
| ESD | EN61000-4-2 Level 3: Air ±8kV, Contact ±6kV | | | | | Perf. Criteria A |
| Radiated immunity | EN61000-4-3 Level 3: 80~1000MHz, 20V/m | | | | | Perf. Criteria A |



CQB50W12 CMFC(D) Series

| | | | |
|---------------------------------|---|---|------------------|
| Fast Transient | EN61000-4-4 | Level 3: On power input port, $\pm 2kV$ | Perf. Criteria A |
| Surge | EN61000-4-5 | Level 4: Line to earth, $\pm 4kV$, Line to line, $\pm 2kV$ | Perf. Criteria A |
| Conducted immunity | EN61000-4-6 | Level 3: 0.15~80MHz, 10V | Perf. Criteria A |
| Interruptions of Voltage Supply | EN50155 | Class S3: 20ms interruptions | Perf. Criteria A |
| Supply Change Over | EN50155 | Class C2: During a supply break of 30ms | Perf. Criteria A |
| Application Note Link | CQB50W12-72S CMFC(D) Series App Notes | | |
| Packaging Information Link | Packaging Information | | |

Immunity to Environmental Conditions.

| Phenomenon | EN50155; 2017 Reference Clause(s) | Reference Standard | Test Conditions | Result |
|---|-----------------------------------|--------------------|---|--------|
| Low Temperature Start-up test | 13.4.4 | EN 60068-2-1 | Class OT4 Temperature: $-40^{\circ}C$ Duration: 2 hrs | Pass |
| Dry Heat Test | 13.4.5 | EN 60068-2-2 | Class OT4 & ST2 Temperature: $70^{\circ}C$ Duration: 6 hrs Extended temperature: $85^{\circ}C$ Extended Duration: 10min | Pass |
| Low Temperature Storage Test | 13.4.6 | EN 60068-2-1 | Temperature: $-40^{\circ}C$ Duration: 16 hrs | Pass |
| Cyclic Damp Heat Test | 13.4.7 | EN 60068-2-30 | Temperature: $25^{\circ}C - 55^{\circ}C$ Humidity: 90 ~ 96% RH Duration: 48 hrs | Pass |
| Random Vibration Test | 13.4.11 | EN 61373 | Temperature: $26^{\circ}C \pm 3^{\circ}C$ Humidity: 50% $\pm 25\%$ RH Frequency range: 5 ~ 150 Hz Vertical: 1.01 m/s^2 Transverse: 0.450 m/s^2 Longitudinal: 0.700 m/s^2 Duration: 10 min / axis | Pass |
| Simulated Long Life Test at Increased Random Vibration Levels | 13.4.11 | EN 61373 | Temperature: $26^{\circ}C \pm 3^{\circ}C$ Humidity: 70% $\pm 5\%$ RH Frequency range: 5 ~ 150 Hz Vertical: 5.72 m/s^2 Transverse: 2.55 m/s^2 Longitudinal: 3.96 m/s^2 Duration: 5 hrs / axis | Pass |
| Shock Test | 13.4.11 | EN 61373 | Temperature: $26^{\circ}C \pm 3^{\circ}C$ Humidity: 70% $\pm 5\%$ RH Frequency range: 5 ~ 150 Hz \pm Vertical: 30 m/s^2 \pm Transverse: 30 m/s^2 \pm Longitudinal: 50 m/s^2 Duration: 30ms x18 (Each axis 3 shocks) | Pass |

EN45545-2 Fire & Smoke Test Conditions.

| Item | Standard | Hazard Level |
|------|--|---------------|
| R22 | Oxygen Index Test EN 45545-2: 2013+A1:2015 EN ISO 4589-2: 2017 | HL1, HL2, HL3 |
| | Smoke Density Test EN 45545-2: 2013+A1:2015 EN ISO 5659-2: 2017 | HL1, HL2, HL3 |
| | Smoke Toxicity Test EN 45545-2: 2013+A1:2015 NF X70-100-1 and -2: 2006 | HL1, HL2, HL3 |
| R23 | Oxygen Index Test EN 45545-2: 2013+A1:2015 EN ISO 4589-2: 2017 | HL1, HL2, HL3 |
| | Smoke Density Test EN 45545-2: 2013+A1:2015 EN ISO 5659-2: 2013 | HL1, HL2, HL3 |
| | Smoke Toxicity Test EN 45545-2: 2013+A1:2015 NF X70-100-1 and -2: 2006 | HL1, HL2, HL3 |
| R24 | Oxygen Index Test EN45545-2: 2013 EN ISO 4589-2 | HL1, HL2, HL3 |
| R25 | Glow - Wire Test EN 45545-2+A1:2016 EN 60695-2-11:2014 | HL1, HL2, HL3 |
| R26 | Vertical Flame Test EN 45545-2: 2013 EN 60695-11-10: 2013 | HL1, HL2, HL3 |



CQB50W12 CMFC(D) Series

CHARACTERISTIC CURVE

Power Derating Curve

CQB50W12-72S CMFC(D) Derating Curve with Heatsink Iron plate (Vin=72V)

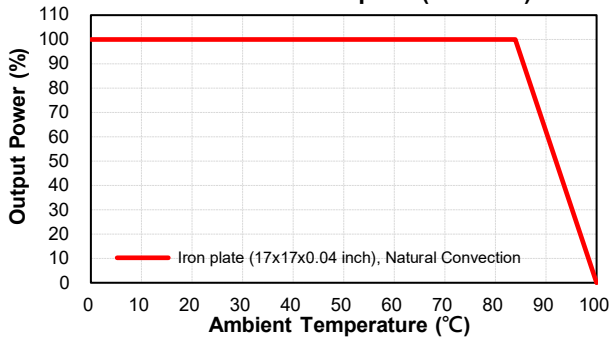

CQB50W12-72S CMFC(D) Derating Curve with Heatsink FBL254 (Vin=72V)

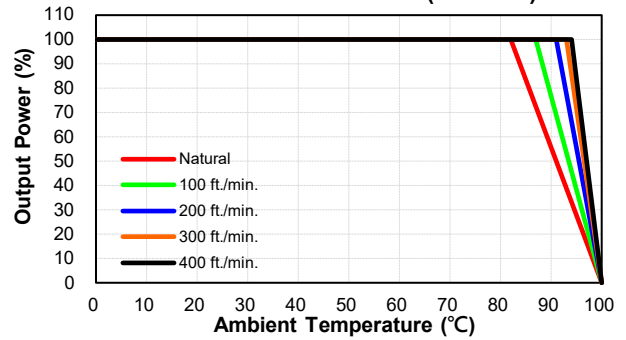

CQB50W12-72S-CMFD+HS(HD) Derating Curve (Vin=72V)

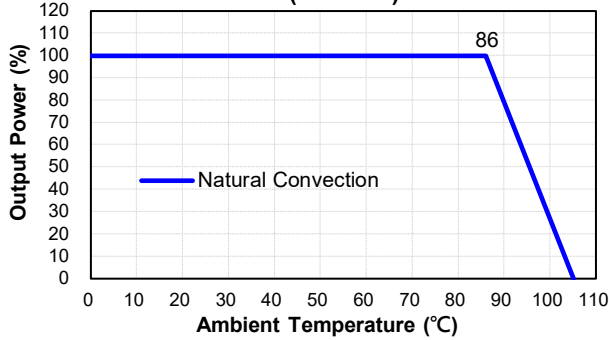

Performance Data

CQB50W12-72S05-CMFC Eff Vs Io @25 Deg. C

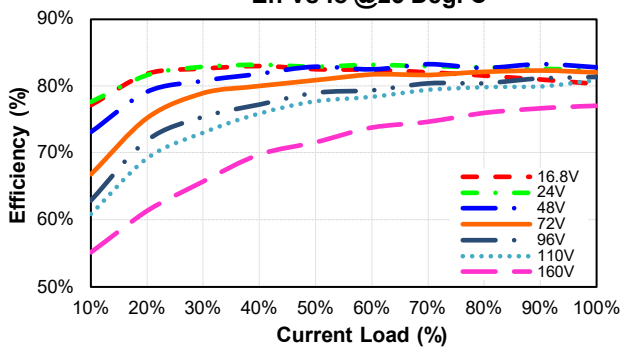

CQB50W12-72S05-CMFC Pd Vs Po @25 Deg. C

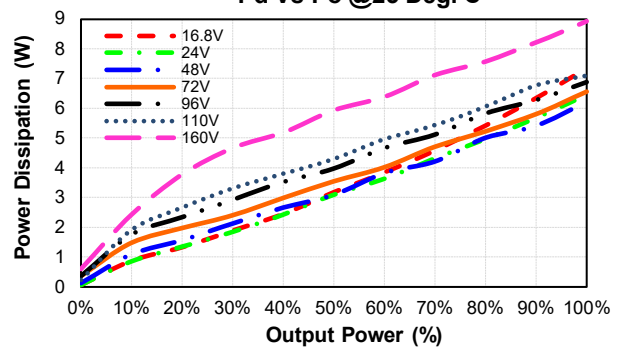



CQB50W12 CMFC(D) Series

CQB50W12-72S12-CMFC
Eff Vs Io @25 Deg. C

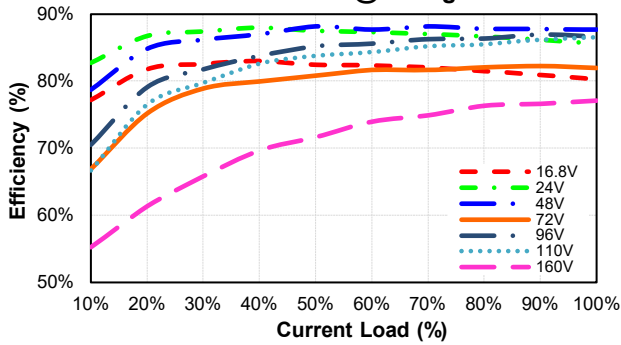

CQB50W12-72S12-CMFC
Pd Vs Po @25 Deg. C

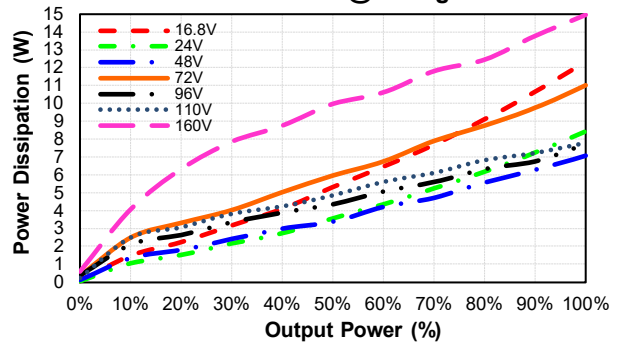

CQB50W12-72S24-CMFC
Eff Vs Io @25 Deg. C

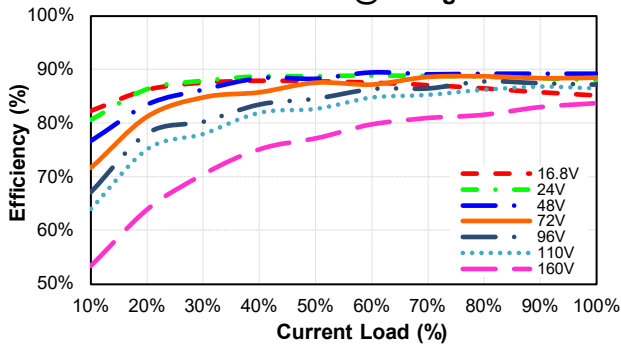

CQB50W12-72S24-CMFC
Pd Vs Po @25 Deg. C

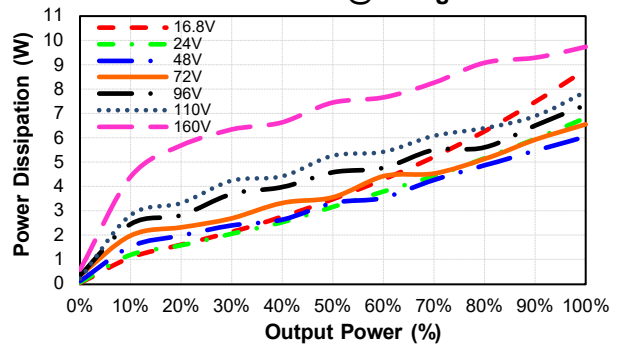

CQB50W12-72S48-CMFC
Eff Vs Io @25 Deg. C

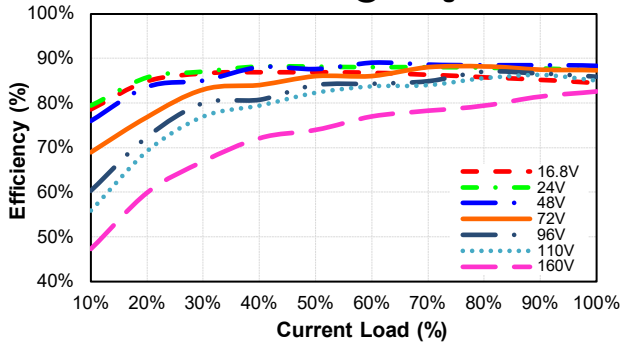

CQB50W12-72S48-CMFC
Pd Vs Po @25 Deg. C

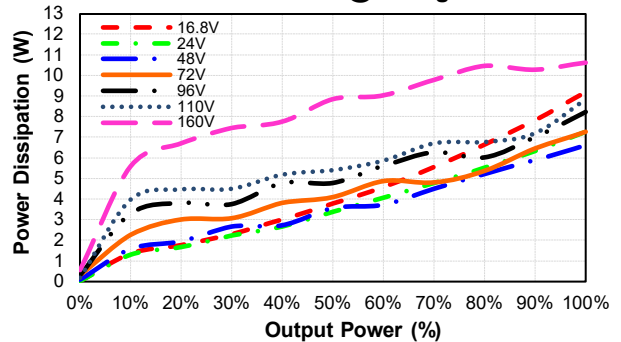



CQB50W12 CMFC(D) Series

MECHANICAL SPECIFICATION

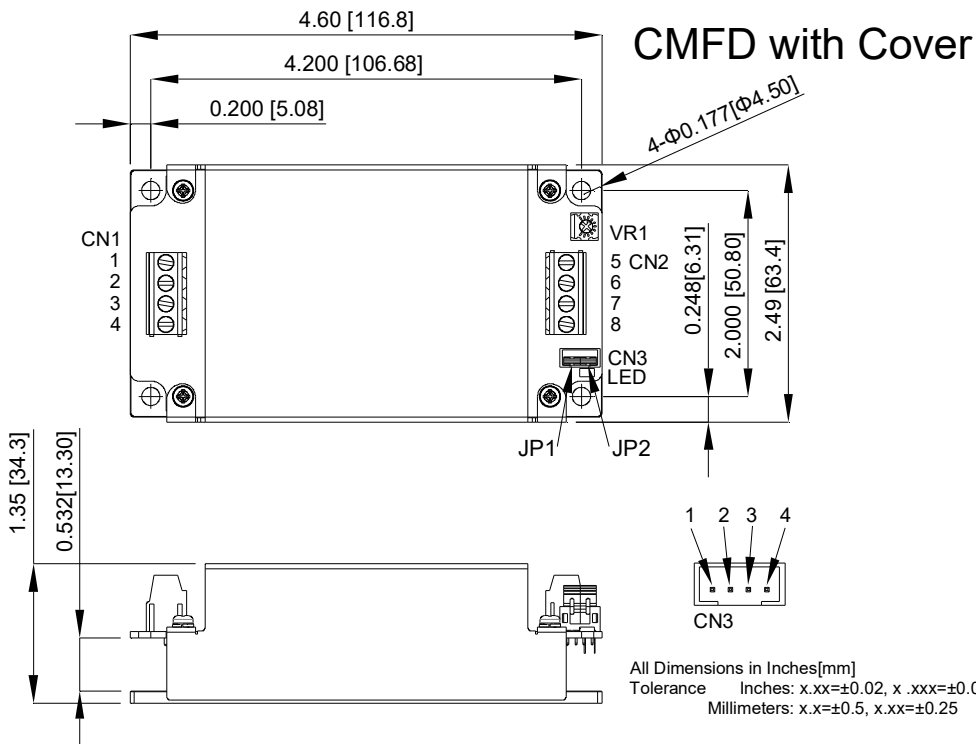
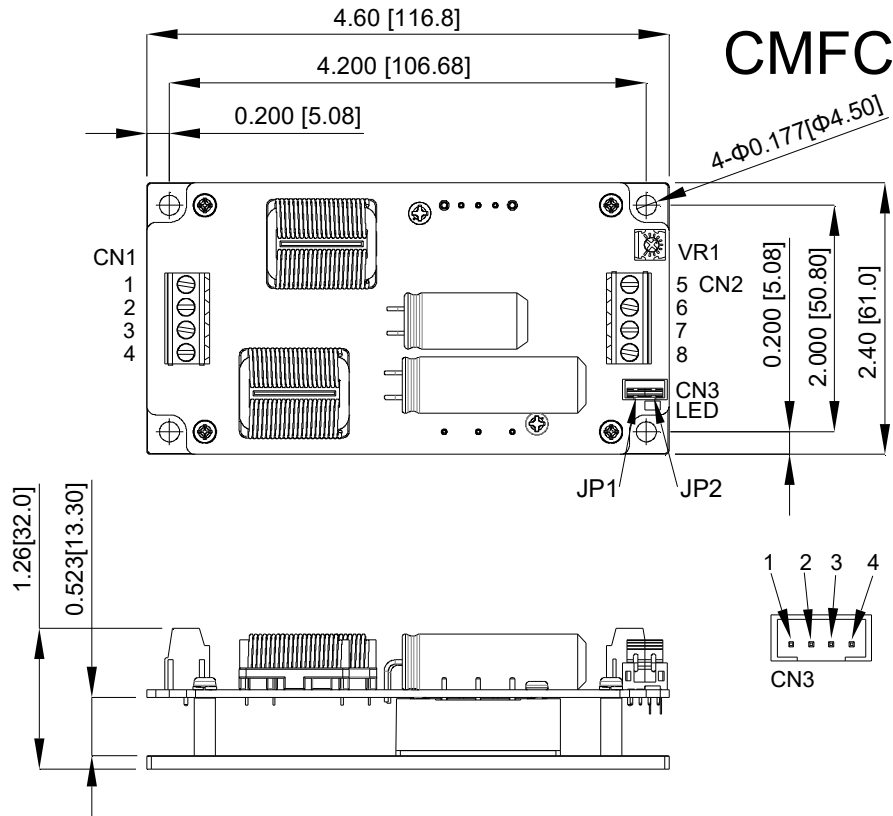

CN1 & CN2
PIN CONNECTION

| PIN | Function |
|-----|-----------|
| 1 | +V Input |
| 2 | -V Input |
| 3 | Remote |
| 4 | Case |
| 5 | +V Output |
| 6 | +V Output |
| 7 | -V Output |
| 8 | -V Output |

CN3
PIN CONNECTION

| PIN | Function |
|-----|-----------|
| 1 | -V Output |
| 2 | -Sense |
| 3 | +Sense |
| 4 | +V Output |

All Dimensions in Inches[mm]
Tolerance Inches: x.xx=±0.02, x.xxx=±0.010
Millimeters: x.x=±0.5, x.xx=±0.25

*JP1:Short PIN1 & PIN2
*JP2:Short PIN3 & PIN4



CQB50W12 CMFC(D) Series

MECHANICAL SPECIFICATION

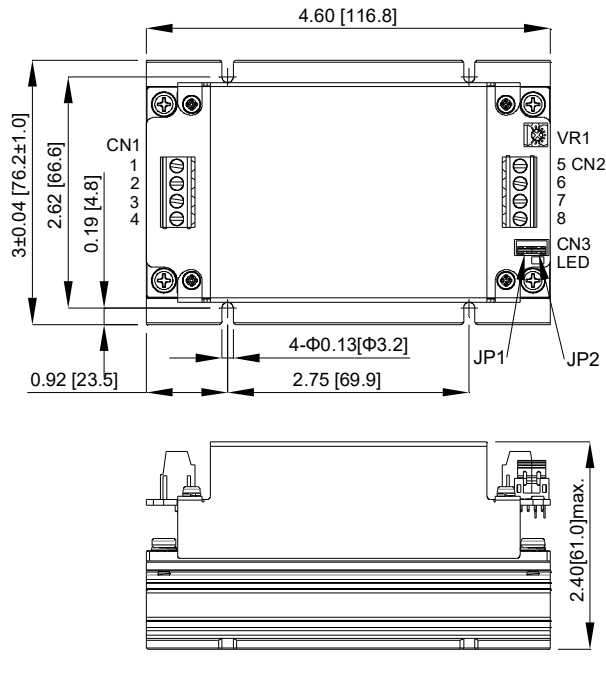

CMFD+HS

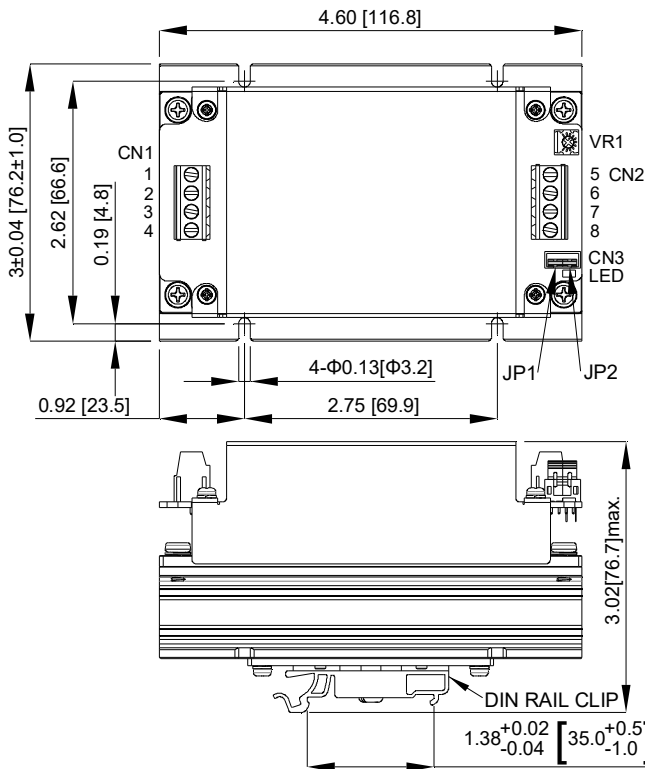
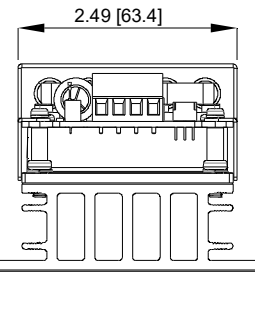
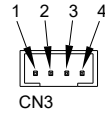

CMFD+HD

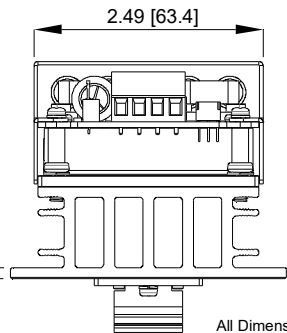
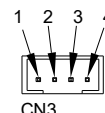

CN1 & CN2 PIN CONNECTION

| PIN | Function |
|-----|-----------|
| 1 | +V Input |
| 2 | -V Input |
| 3 | Remote |
| 4 | Case |
| 5 | +V Output |
| 6 | +V Output |
| 7 | -V Output |
| 8 | -V Output |

CN3 PIN CONNECTION

| PIN | Function |
|-----|-----------|
| 1 | -V Output |
| 2 | -Sense |
| 3 | +Sense |
| 4 | +V Output |

*JP1: Short PIN1 & PIN2
*JP2: Short PIN3 & PIN4

All Dimensions in Inches[mm]
Tolerance Inches: x.xx=±0.02, x.xxx=±0.010
Millimeters: x.x=±0.5, x.xx=±0.25