



Hi-Rel HOLD-UP MODULE HUGD-50 : 50W POWER

Hi-Rel Grade ■■

Hold-Up Solution 9-36V & 16-40V DC/DC Converter Compatible Metallic Case

- Unique Product for Hold-Up Solution
- Reduce Capacitance by 80%
- High efficiency (98%)
- Power range : from 4W to 50W
- Compatible with 9-36 or 16-40VDC Converter
- Include monitoring signals
- Programmable inrush current limitation
- RoHS or Leaded process option



1-General

The GAIA Converter Hold up device HUGD-50 provides a state-of-the-art solution to the problem of maintaining electronic system in operation during input bus drop-out for enough time. Usually this approach uses very large capacitors because they are only charged at the voltage at which power fails. The Gaia Converter HUGD-50 module provides an alternative solution to reduce the amount of capacitance needed by charging the hold up capacitor at a high voltage (typically 38V) while limiting the input current.

The HUGD-50 must be connected between the line source and DC/DC modules. If an EMI filter and /or a pre-regulator are used, the HUGD-50 is connected between them and the converters. Basically the HUGD-50 charges the external capacitor to 38V while powering the DC/DC converters. If the power fails, the HUGD-50 generates a signal and the converters are powered from the external capacitor. The HUGD-50 can be used either with 16-40V or 9-36V input voltage DC/DC converters since the «power fail voltage» is externally adjustable by the user between 8.8V and 15.3V .

The HUGD-50 features 3 modes of operations:

- Charging operation mode : when the input voltage ramps-up and reaches the start-up charge threshold (which is set at 1Vdc above

the «power fail voltage»), the HUGD-50 begins to charge the external capacitor at 38 VDC while powering the dc/dc converter. The charging current is controlled and externally adjustable between 100mA and 2A by a resistor. The capacitor charging time depends on the charging current. When the capacitor voltage reaches 35V, the signal (active low, open-drain) «capacitor charged» is activated and the HUGD-50 enters in the normal operation mode.

- Normal operation mode : in normal operation mode when the capacitor is charged and the input bus is between the «output power fail» and 40VDC, the HUGD-50 only consumes power to keep the capacitor charged (i.e. less than 1W). The voltage drop between input and output is lower than 150mV in the worst case (50W power and 9 VDC input voltage) The HUGD-50 will operate indefinitely in this state until the input voltage drops below the «power fail voltage» threshold.

- Power fail mode : when the input voltage drops below the «power fail voltage» threshold, a «power fail» signal is activated and the HUGD-50 disconnects input from output and connects the hold-up capacitor to the output. At this point the DC/DC converters are powered by the capacitor. When its voltage finally discharges to a value slightly above the «power fail voltage» threshold value, a «capacitor discharged» flag is activated.

2-Product Selection

HUGD - 50 - / -

Options :

- /T : option for -55°C start up operating temperature
- /S : option for screening and serialization

Suffix :

- nothing : RoHS process
- L : leaded process (available in N. America)

3- Block Diagram

The HUGD-50 module includes 3 main circuits :

- an input monitoring circuit
- an hold-up charger circuit
- a hold-up monitoring circuit

• **Input monitoring Circuit :**

The input monitoring circuit monitors the value of the input bus voltage and compares it to the power fail threshold voltage (V_{th}) set externally through a resistor. Depending on this comparison, the circuit enables the activation of the hold-up switch or the hold-up charger and generates an open-drain «power fail flag (PF)».

• **Hold-up Charger :**

The hold-up charger is used to feed the hold-up capacitor with a constant $V_c=38V$ voltage. The design of this charger has been optimized to minimize the input inrush current which can be set externally through the V_{cl} input by a resistor.

• **Hold-up monitoring Circuit :**

The hold-up monitoring circuit monitors the charging status of the hold-up capacitor.

The circuit generates 2 open-drain flags : the capacitor charged flag (CC) and the capacitor discharged flag (CD).

These flags can be used at system level for power interruption management (VME system, PCI, ...).

The following diagram represents the HUGD-50 series block diagram.

HUGD-50 Block Diagram

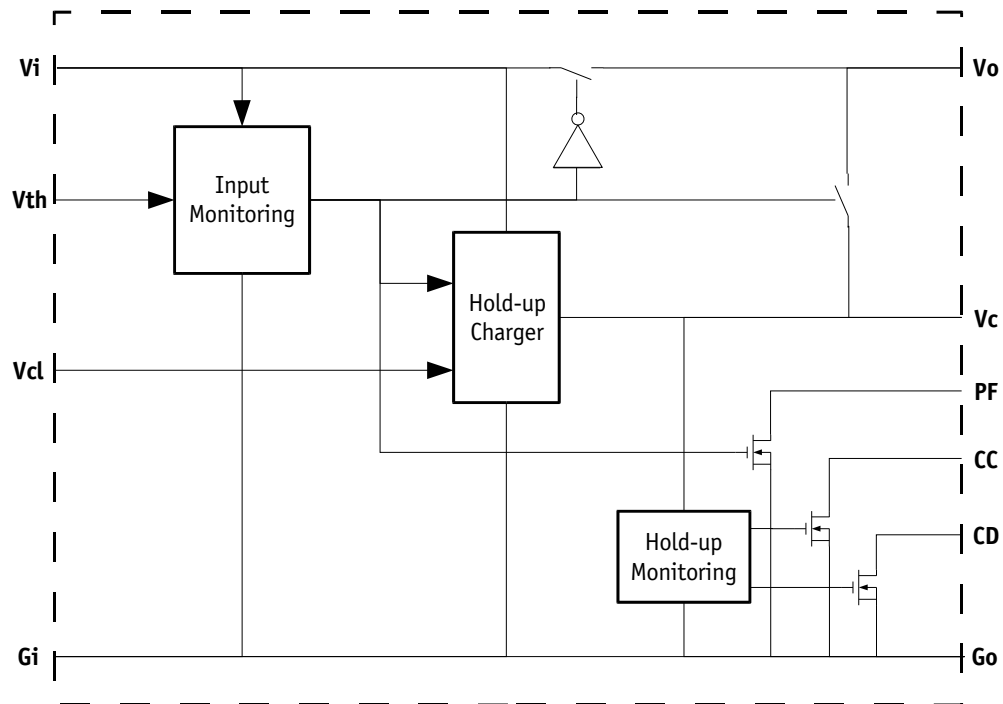



4- Electrical Specifications

Data are valid at +25°C, unless otherwise specified.

Parameter	Conditions	Limit or typical	Units	HUGD-50
Input				
Permanent input voltage range (Ui)	Full temperature range Full load	Minimum	VDC	9
		Maximum	VDC	40
Transient input voltage	Full temperature range Full load	Maximum	VDC/ms	50/100
Power fail voltage threshold (Vfail)	with the setting Vth unconnected	Minimum	VDC	15
		Typical	VDC	15,3
		Maximum	VDC	15,6
Power fail voltage threshold (Vfail)	with the setting Vth connected to ground	Minimum	VDC	8,6
		Typical	VDC	8,8
		Maximum	VDC	9
Power fail hysteresis	/	Typical	VDC	1
Input current consumption during charging at 28V	min: Vcl unconnected max: Vcl connected to ground	Minimum	A	0,1
		Maximum	A	1,5
Input current consumption during charging at 16V	min: Vcl unconnected max: Vcl connected to ground	Minimum	A	0,1
		Maximum	A	2,2
Output				
Output power	Full temperature range Full load	Maximum	W	50
Output current	Full temperature range Ui min. to max.	Maximum	A	5,6
Dissipated power	Vin @ 9V, full power	Maximum	W	2
Voltage drop input/output	Vin @ 9V, full power	Maximum	mV	160
Capacitor charged signal (CC) threshold	Turn off threshold Turn on threshold	Typical	VDC	30,5
		Typical	VDC	35
Capacitor discharged signal (CD) threshold	with setting Vth unconnected	Minimum	VDC	15,9
		Maximum	VDC	16,7
Capacitor discharged signal (CD) threshold	with setting Vth connected to ground	Minimum	VDC	9,4
		Maximum	VDC	10,2
CC, CD, PF sink current	/	Maximum	mA	25
Admissible hold-up capacitor	/	Minimum	μF	470
		Maximum	μF	30 000
Hold-up time at 50W load	Vth unconnected Vth connected to ground	Minimum	μs/μF	11,2
		Minimum	μs/μF	12,8
Hold-up time at 10W load	Vth unconnected Vth connected to ground	Minimum	μs/μF	55,6
		Minimum	μs/μF	64,4

5- Switching Frequency

Parameter	Conditions	Limit or typical	Specifications
Switching frequency	Full temperature range Ui min. to max. No load to full load	Nominal, fixed	200 KHz

6- Isolation

Parameter	Conditions	Limit or typical	Specifications
Electric strength test voltage	Input to output	/	No isolation

7- Reliability Data

Characteristics	Conditions	Temperature	Specifications
Mean Time Between Failure (MTBF) According to MIL-HDBK-217F	Ground fixed (Gf)	Case at 40°C Case at 85°C	1 500 000 Hrs 590 000 Hrs
	Airborne, Inhabited, Cargo (AIC)	Case at 40°C Case at 85°C	730 000 Hrs 300 000 Hrs
Mean Time Between Failure (MTBF) According to IEC-62380-TR	Civilian avionics, calculators	Ambient at 55°C 100% time on	Consult factory

8- Thermal Characteristics

Characteristics	Conditions	Limit or typical	Performances
Operating ambient temperature range at full load	Ambient temperature *	Minimum Maximum	- 40°C + 90°C
Operating case temperature range at full load	Case temperature	Minimum Maximum	- 40°C +105°C
Storage temperature range	Non functioning	Minimum Maximum	- 55°C + 125°C
Thermal resistance	Rth case to ambient in free air natural convection	Typical	12°C /W

Note * : The upper temperature range depends on configuration, the user must assure a max. case temperature of + 105°C.

The HUGD-50 series operating **case** temperature must not exceed 105°C. The maximum **ambient** temperature admissible for the DC/DC converter corresponding to the maximum operating case temperature of 105°C depends on the ambient airflow, the mounting/orientation, the cooling features and the power dissipated.

To calculate a maximum admissible ambient temperature the following method can be used. Knowing the maximum case temperature Tcase = 105°C of the module, the power used Pout and the efficiency η :

- determine the power dissipated by the module P_{diss} that should be evacuated :

$$P_{diss} = P_{out} / (\eta - 1)$$

- determine the maximum ambient temperature :

$$T_a = 105^\circ\text{C} - R_{th} \times P_{diss}$$

where **Rth** is the thermal resistance from the case to ambient.

The previous thermal calculation shows two areas of operation :

- a normal operation area in a free natural ambient convection (grey area in this following graph),
- an area with cooling features (air flow or heatsink) ensuring a maximum case temperature below the maximum operating case temperature of 105°C (white area in the following graph).

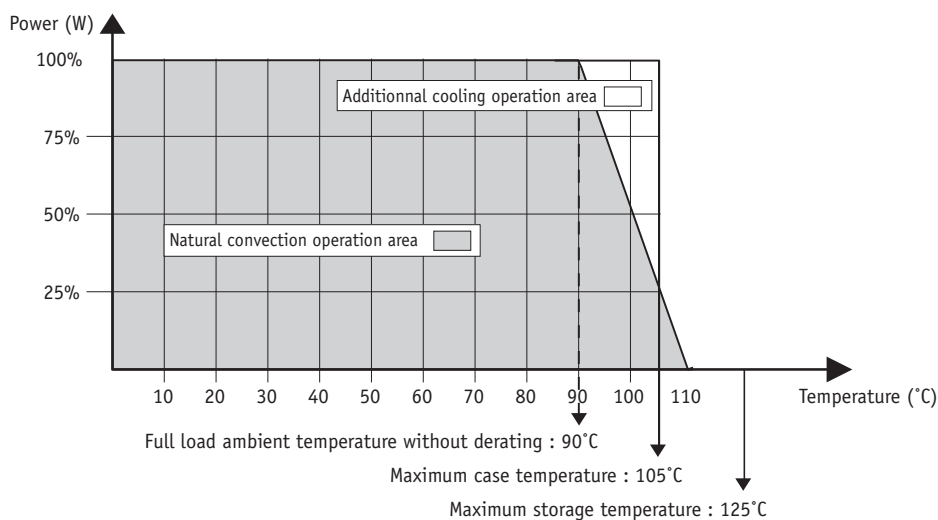

9- Environmental Qualifications

The modules have been subjected to the following environmental qualifications.

Characteristics	Conditions	Severity	Test procedure
Climatic Qualifications			
Life at high temperature	Duration Temperature / status of unit	Test D : 1 000 Hrs @ 105°C case, unit operating @ 125°C ambient, unit not operating	MIL-STD-202G Method 108A
Altitude	Altitude level C Duration Climb up Stabilization Status of unit	40 000 ft@-55°C 30 min. 1 000 ft/min to 70 000 ft@-55°C, 30 min. unit operating	MIL-STD-810E Method 500.3
Humidity cyclic	Number of cycle Cycle duration Relative humidity variation Temperature variation Status of unit	10 Cycle I : 24 Hrs 60 % to 88 % 31°C to 41°C unit not operating	MIL-STD-810E Method 507.3
Humidity steady	Damp heat Temperature Duration Status of unit	93 % relative humidity 40°C 56 days unit not operating	MIL-STD-202G Method 103B
Salt atmosphere	Temperature Concentration NaCl Duration Status of unit	35°C 5 % 48 Hrs unit not operating	MIL-STD-810E Method 509.3
Temperature cycling	Number of cycles Temperature change Transfert time Steady state time Status of unit	200 -40°C / +85°C 40 min. 20 min. unit operating	MIL-STD-202A Method 102A
Temperature shock	Number of shocks Temperature change Transfert time Steady state time Status of unit	100 -55°C / +105°C 10 sec. 20 min. unit not operating	MIL-STD-202G Method 107G
Mechanical Qualifications			
Vibration (Sinusoidal)	Number of cycles Frequency / amplitude Frequency / acceleration Duration Status of unit	10 cycles in each axis 10 to 60 Hz / 0.7 mm 60 to 2 000 Hz / 10 g 2h 30 min. per axis unit not operating	MIL-STD-810D Method 514.3
Shock (Half sinus)	Number of shocks Peak acceleration Duration Shock form Status of unit	3 shocks in each axis 100 g 6 ms 1/2 sinusoidal unit not operating	MIL-STD-810D Method 516.3
Bump (Half sinus)	Number of bumps Peak acceleration Duration Status of unit	2 000 Bumps in each axis 40 g 6 ms unit not operating	MIL-STD-810D Method 516.3

10- Application Notes

10-1 General on Input Bus Shut-Down Requirements

During bus power drop-out, avionics and military systems require a maintain of operation for data saving and shut-down control.

The duration of this shut-down operation is defined in different standards and can last up to 7 secondes.

10-1-1 Capacitor Stand-Alone Solution

To maintain operation during power drop-out, the traditional approach is to use a bulk capacitor connected at the input of the converters to power them when power drops-out. This capacitor depends on the system specifications, the load, the efficiency of the DC/DC converter and the hold-up time requirement. The value of the capacitance is determined by the following formula :

$$C1 = \frac{2 \times P \times Dt}{(V1^2 - V2^2)}$$

where :

- C : is the required capacitor (in farads)
- P : is the consumed power (at HUGD output)
- Dt : is the required hold up time (in seconds)
- V1 : is the initial charged capacitor voltage (in volts)
- V2 : is the low line voltage of DC/DC converter

For a typical 50ms hold-up time requirement on 50W output DC/DC converter with 80% efficiency - i.e 62,5W consumed power - with a minimum permanent input voltage of 16V connected on a standard MIL-STD-704 28V bus that can range down to 22V, the resulting capacitor is a large 27 400uF/40V.

10-1-2 Capacitor with Hold Up Module Solution

To reduce drastically the size of this capacitor, GAIA Converter proposes the HUGD-50 hold up module that will charge the capacitor at a higher voltage, typically 38V.

Moreover this module also allows to select the minimum threshold voltage at which the capacitance will power the converters. In this case the amount of capacitance needed for a given hold up time is determined by the following formula :

$$C2 = \frac{2 \times P \times Dt}{(38^2 - V2^2)}$$

where :

- C : is the required capacitor (in farads)
- P : is the consumed power (at output of HUGD) (in watts)
- Dt : is the required hold up time (in seconds)
- V2 : is the low line voltage of DC/DC converter (in volts).

For a typical 50ms hold-up time requirement on 50W output DC/DC converter with 80% efficiency - i.e 62,5W consumed power - with a minimum permanent input voltage of 16V connected on a MIL-STD-704 28V bus, using the HUGD-50 will reduce the capacitor value down to 6 300uF/40V.

10- Application Notes (continued)

10-2 Hold-up Capacitor Selection with HUGD-50 Solution

The external capacitor supplies the energy for the DC/DC converters operation during power drop-out. The capacitance should not exceed 30.000µF, and should be higher than 470µF. The amount of capacitance for a given hold up time is given by the formula :

$$C = \frac{2 \times P (Dt + 0.01)}{38^2 - V_L^2}$$

where

- C : is the required capacitance (in Farads)
- P : is the consumed power (at the output of HUGD) (in Watts)
- Dt : is the required hold-up time (in seconds). 10ms are added for design margin
- V_L : is the lowest admissible voltage of DC/DC converters (in volts)

The following curve gives the hold up time as a function of the capacitor value. Gaia Converter recommends a low ESR extended temperature range electrolytic capacitor.

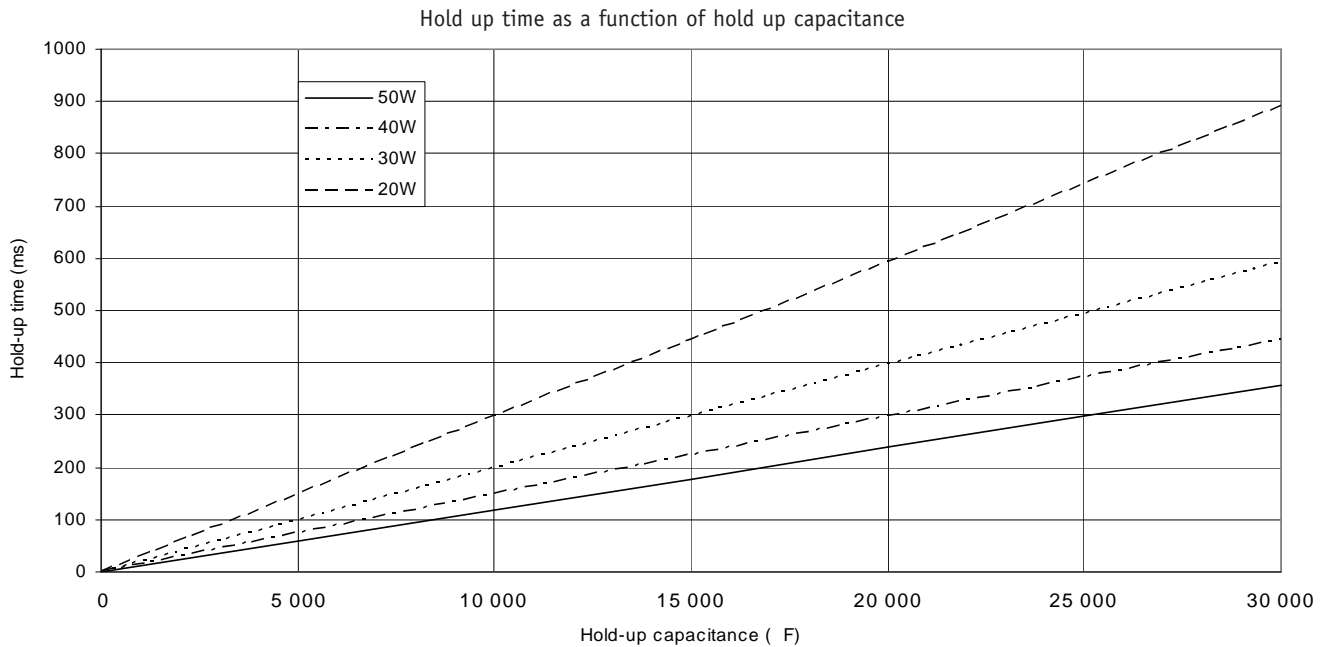

10- Application Notes (continued)

10-3 Power Fail Voltage Threshold : Vth

The «power fail voltage» threshold determines the operation mode of the HUGD-50.

This threshold has to be set up in conjunction with the type of modules used (i.e. 9-36 VDC or 16-40 VDC input voltage type of modules) and can be adjusted between 8,8VDC and 15,3VDC by an external resistor Rth connected between the Vth pin and Gout pin.

Vth unconnected will set the threshold at 15,3VDC valid for 16-40Vdc input modules whereas Vth connected to ground will set the threshold at 8,8VDC valid for 9-36Vdc input modules.

If the HUGD-50 is used with the PGDS-50-N-K, Vth has to remain unconnected; with the PGDS-50-O-K, Vth has to be connected to Go. The following curve shows the Vth function threshold as a function of the resistor Rth.

The hysteresis on the undervoltage detection is typically 1V. Once an undervoltage has been detected and the input bus has been disconnected to switch on the hold-up capacitor energy reservoir, the HUGD-50 will reconnect the input bus when it is 1V above the value set with the Vth pin. Therefore, it is recommended to minimize the series resistance of elements in front of the HUGD-50 to prevent false triggerings when the input current becomes 0A as the Vth threshold is reached and the bus is disconnected, because the voltage at the input of the HUGD-50 will then slightly increase. The resulting unwanted bounces may lead to a loss of stored energy and internal switch overstress. The series resistance should be kept below $0,75 \times Vth / Pout$.

Power fail voltage threshold versus Rth

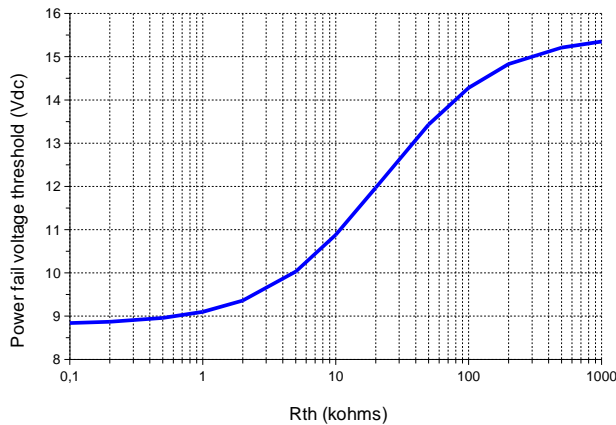

10-4 Charging Current Setting : Vcl

The HUGD-50 controls the charging current to remain between 100 mA to 2A by an external resistance Rcl connected between the Vcl pin and the Gout pin. This charging current is a direct function of the charging time

knowing that the capacitor is charged at 38VDC. The following curve gives the resistance Rcl value as a function of current & charging time.

Input charging current as function of external resistor Rcl

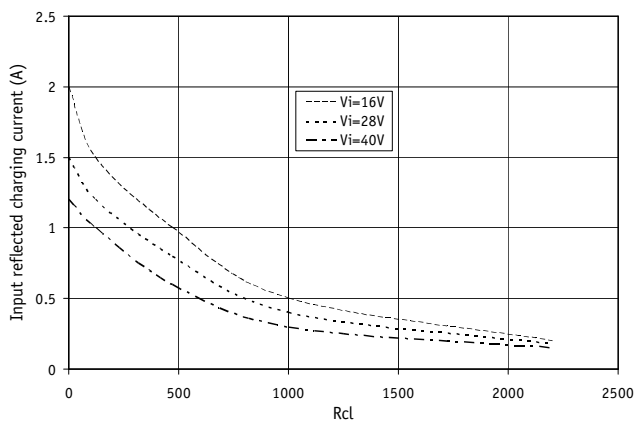

Input charging rate as function of external resistor Rcl

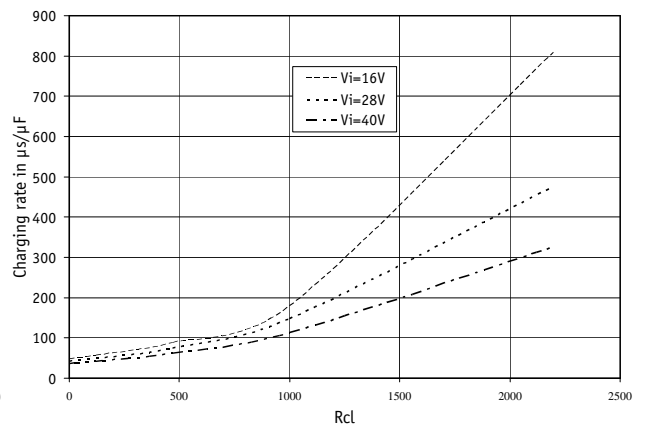

10- Application Notes (continued)

10-5 Power Fail Signal : PF

The «power fail» output signal is activated when the voltage drops below the power fail voltage threshold. The PF signal is an active low open-drain output.

10-6 Capacitor Discharged Signal : CD

The «Capacitor discharged» signal is activated when the voltage at the hold-up capacitor pin reaches the value programmed with the Vth pin + 0.9V to inform the system that the energy storage capacitor voltage is closed to the value which is considered a «power fail» event. It can be used as a last warning before system shut-off. With the Vth pin unconnected, the corresponding value will be $V_c = 16.2V$, whereas with the Vth pin grounded, the corresponding value will be $V_c = 9.7V$.

The CD signal is an open drain active low output.

10-7 Capacitor Charged Signal : CC

The «capacitor charged» signal is activated when the voltage at the capacitor pins reaches 35 VDC corresponding to an energy stored of about 90% of its full charge. The CC signal is an active low open-drain output.

10-8 Transition Capacitor

To help transitioning the system in the different operating mode, GAIA Converter recommends the use of a transition capacitor. This capacitor is used to maintain output voltage during the HUGD-50 switching from input line to hold up capacitor. A 100µF electrolytic capacitor is enough for a 50W load, and this value can be reduced for lower loads.

The table below gives the minimum required values versus output power :

Output power (W)	10	20	30	40	50
Capacitance value (µF)	22	47	68	82	100

10-9 Typical Schematics

This typical application schematics includes an EMI filter, a PGDS-50 pre-regulator, the hold-up module and an assembly of standard DC/DC converters. Additional details are given in the EMI filters application notes and PGDS-50 datasheet.

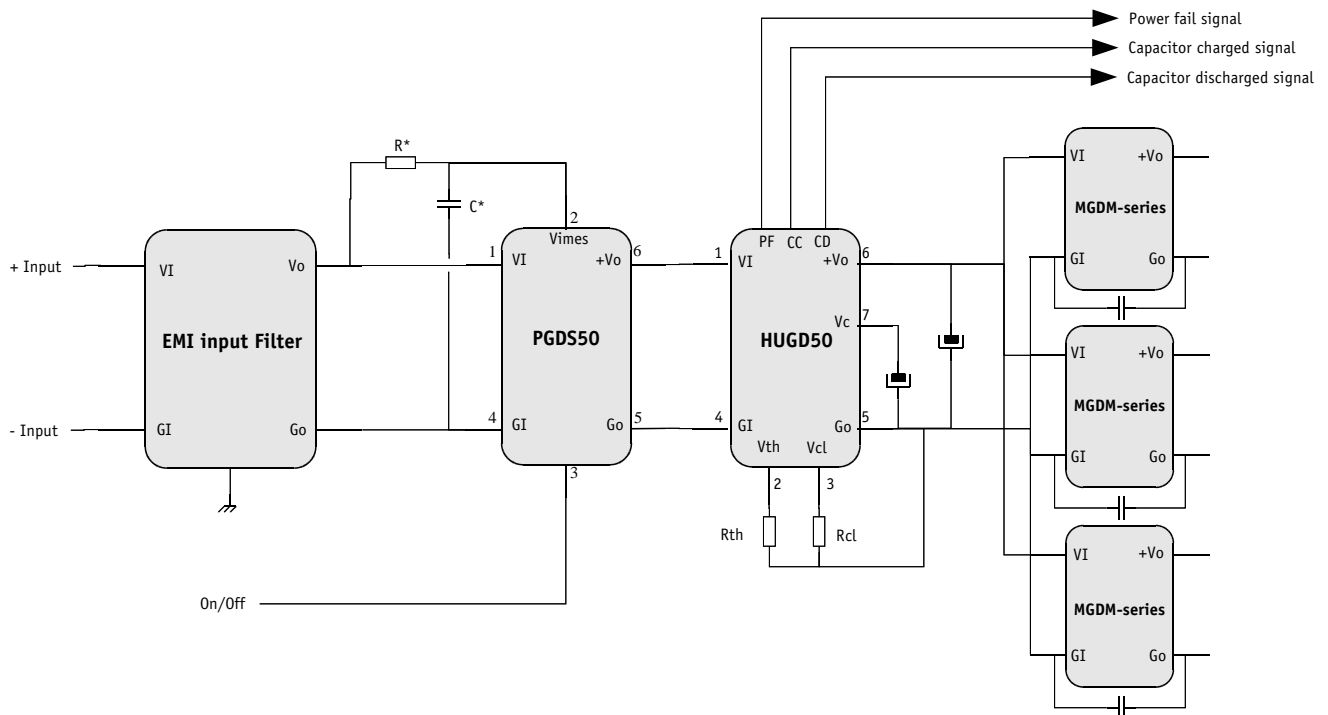

Note * : Due to possible oscillations caused by surges or fast transients at the input voltage level, it is recommended to implement a RC filter on the VIMES signal; several implementations as shown in the above figure can be tested to optimize the design. Typical values for the resistor R is 470 Ohm and for the capacitance C is 1µF.

10- Application Notes (continued)

10-10 Timing Diagram

The following diagram describes the HUGD-50 output signals through the different operation modes :

- Input voltage (V_i)
- Output voltage to DC/DC converter (V_o)
- Power Fail signal (PF)
- Capacitor voltage (V_c)
- Capacitor charged signal (CC)
- Capacitor discharge signals (CD)

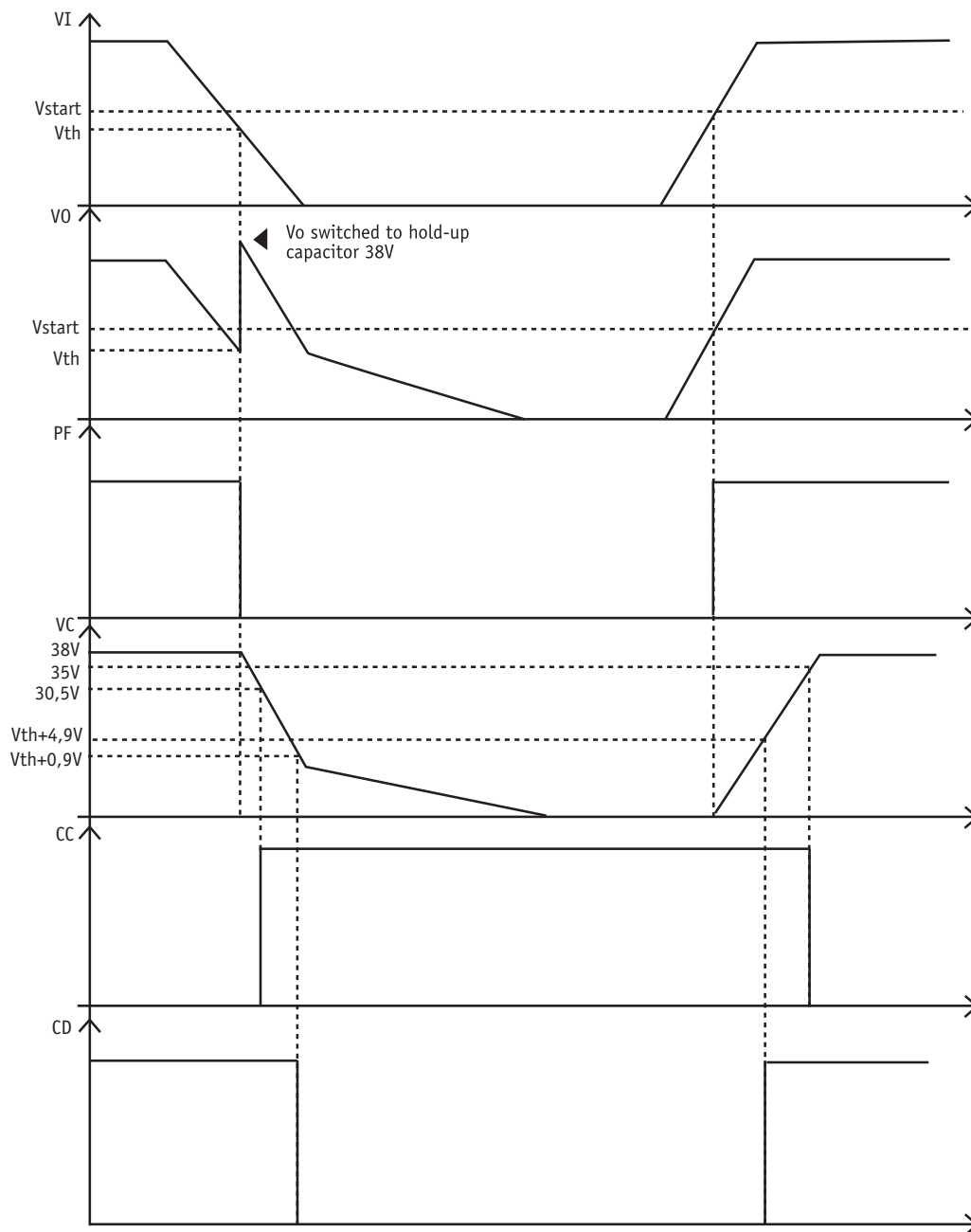

11- Dimensions

Dimension are given in mm (inches). Tolerance : +/- 0,2 mm (+/- 0.01 ") unless otherwise indicated.
Weight : 20 grams (0.7 Ozs) max.

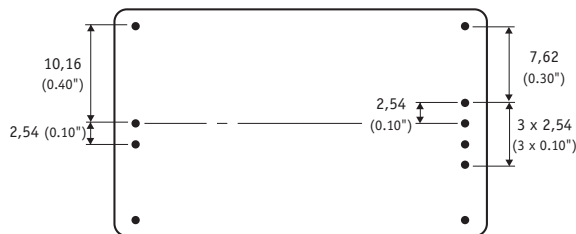
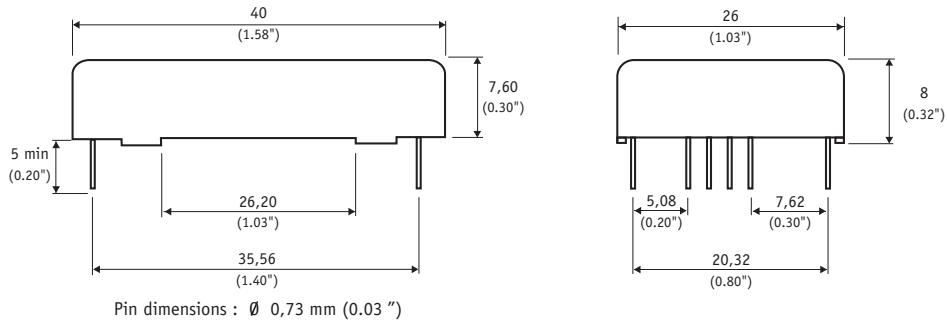

12- Materials

Case : Metallic black anodized coating.
Pins : Plated with pure matte tin over nickel underplate.

13- Product Marking

Upper face : Company logo.
Side face : Module reference : HUGD-50.
Date code : year and week of manufacturing, suffix, /option.

14- Connections



Bottom view

Pin	HUGD-50
1	+ Input (Vi)
2	Power Fail Threshold (Vth)
3	Voltage Current Level (Vcl)
4	- Input (Gi)
5	Common (Go)
6	Output (Vo)
7	Voltage Capacitor (Vc)
8	Power Fail Signal (PF)
9	Capacitor charged signal (CC)
10	Capacitor discharged signal (CD)



Represented by :

Information given in this datasheet is believed to be accurate and reliable. However, no responsibility is assumed for the consequence of its use nor for any infringement of patents or other rights of third parties which may result from its use. These products are sold only according to GAIA Converter general conditions of sale, unless otherwise confirmed by writing. Specifications subject to change without notice.