



Hi-Rel PRE-REGULATOR MODULE PGDS-50 : up to 50W POWER

Hi-Rel
Grade ■■

Brown-out/Transient 10-80V or 6-100V Protection Module DO-160, MIL-STD-704, MIL-STD-1275 Metallic Case

- Transient suppressor module 80V
 - MIL-STD-704A/D/E/F, EN2282, AIR2021E
 - D0160D cat A, B and Z
- Transient suppressor module 100V
 - MIL-STD-1275A/B,
- Extended operation for voltage drop out and cranking down to 6V
- Power range : from 4W to 50W
- Inhibition function
- RoHS or Leaded process



1- General

The GAIA Converter pre-regulator PGDS-50 series designates a low profile power adaptor module designed to extend input bus voltage to meet system operation during voltage transients, spikes, cranking and drop out occurring in avionics or military systems.

The PGDS-50 delivers an output voltage adapted to GAIA Converter DC/DC modules. This line of module is optimized to provide high power efficiency up to 96% over the whole power range between 4W and 50W.

The PGDS-50 features 4 modes of operations as follow:

- **Low line operation :**

Low line operation occurs when the input bus voltage drops down below the permanent input voltage range of the DC/DC converter ; then the PGDS-50 operates in «boost» mode to provide an output voltage compatible with DC/DC converter.

The PGDS-50 series can sustain low line operation down to 6V.

- **Power fail operation :**

An undervoltage lock-out stops operation and disables the «boost» mode for voltage below this low line operation.

- **Normal operation :**

Normal operation occurs between the permanent input voltage of DC/DC converter; The module is then operating in steady transparency state.

- **Transient operation :**

The PGDS-50 series clamps input transient up to 80V/100ms or 100V/50ms.

The PGDS-50 series is compliant with the international input bus standards :

- MIL-STD-704A/D/E/F
- AECMA EN2282
- GAM-EG13B/AIR2021E
- D0160D cat A, B and Z
- MIL-STD-1275A/B

The design has been carried out with surface mount components and is manufactured in a fully automated process to guaranty high quality. Every module is tested with a Gaia Converter automated test equipment. The modules are potted with a bi-component thermal conductive compound and packaged in a metallic case to ensure the module's integrity under high environmental conditions.

2- Product Selection

PGDS - 50 - - / -

Input Voltage Range

Brown-out - Transient

N : 10V/30s - 80V/100ms
O : 6V/1s - 100V/50ms

Output

K

Options :

/T : option for -55°C start up operating temperature
/S : option for screening and serialization

Suffix :

nothing : RoHS process
-L : leaded process (available in N. America)

3- Block Diagram

The PGDS-50 module includes 3 main circuits :

- A Boost Circuit
- An Active clamping Circuit
- A Control Circuit

• **Boost Circuitry :**

The boost circuit operates when the input bus voltage drops-down (low line operation) and boost the input voltage to a higher output value.

• **Active Clamping :**

The active clamping circuit operates when the input bus voltage increases (transient & spike operation). The circuitry clamps the input voltage to typically 38Vdc.

• **Control Circuit :**

The control circuit monitors the different modes of operation through the V_{imes} signal and allows the functioning of the active clamping circuit or the boost circuit.

The PGDS-50 series features 4 modes of operations :

- Power fail operation
- Low line operation
- Normal operation
- Transient & surge operation

The following figure represents the PGDS-50 series block diagram while the table hereafter describes the circuitry activation depending on the 4 modes of operations.

PGDS-50 Block Diagram

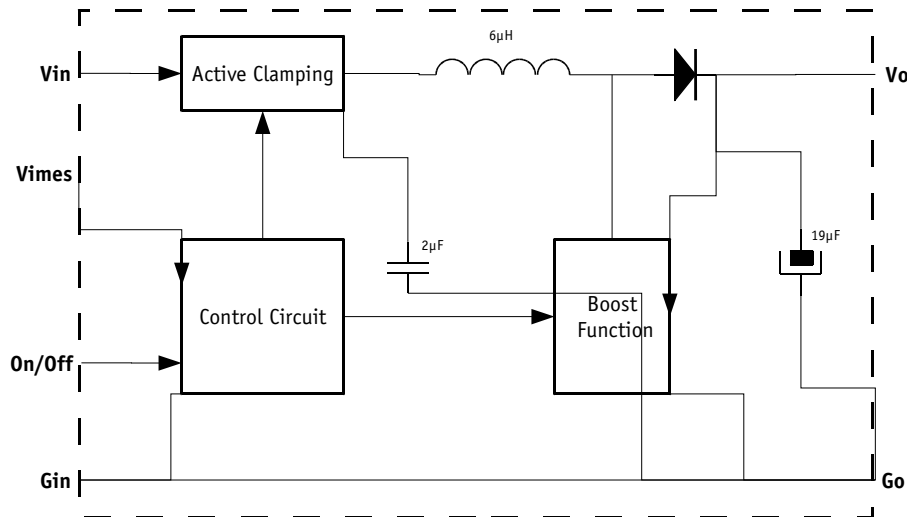

PGDS-50 Modes of Operation

Modes of Operation	Control Circuit	Boost Circuit	Active Clamping Circuit
Power Fail Operation	Off	Off	Off
Low Line Operation	On	On	Off
Normal Operation	On	Off	Off
Transient & Surge Operation	On	Off	On

4- Modes of Operation

4-1 PGDS-50-N-K Modes of Operation

The PGDS-50-N-K operates with J input (i.e 16-40Vdc) family of GAIA Converter DC/DC Converters. The PGDS-50-N-K features 4 modes of operations as follow :

- **Low line operation :**

Low line operation occurs when the input bus voltage drops down below the permanent input voltage range of the DC/DC converter i.e 16 Vdc. The PGDS-50-N-K then operates in boost mode to provide an output voltage compatible with the DC/DC converter. The PGDS-50-N-K series can sustain low line operation down to 10V during 30 sec.

- **Power fail operation :**

An undervoltage lock-out stops operation for voltage below this low line operation threshold.

- **Normal operation :**

Normal operation occurs between the permanent input voltage of DC/DC converter; The module is then operating in steady transparency state.

- **Transient operation :**

The PGDS-50-N-K clamps input transient up to 80V as long as 100ms.

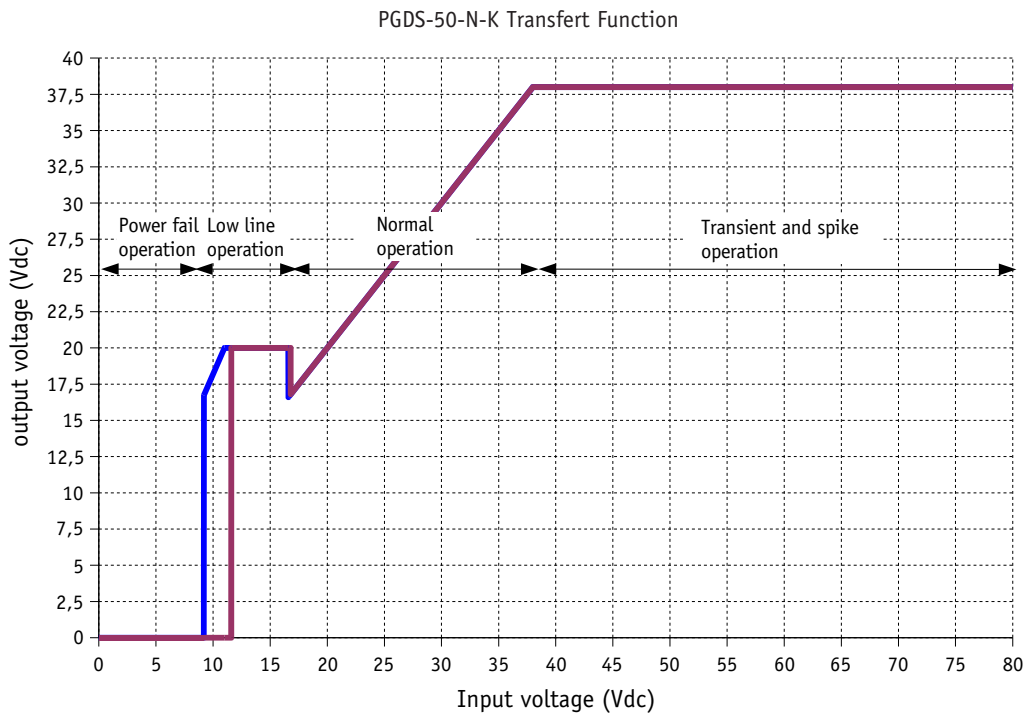

Parameter	Unit	Min.	Typ.	Max.	Notes, conditions
Power Fail Operation :					
Undervoltage Lockout On	Vdc	11,25	/	12	/
Undervoltage Lockout Off	Vdc	8,80	/	9,50	/
Low Line Operation :					
Voltage Low Line Operation On	Vdc	16,30	/	17	/
Voltage Low Line Operation Off	Vdc	16,40	/	17,2	/
Maximum output power at 10V@30sec	W	/	/	36	see page 6
Normal operation :					
Maximum output power	W	/	/	50	see page 6
Transient & Surge Operation :					
Maximum output power at 80V/100ms	W	/	/	50	see page 6

4- Modes of Operation (continued)

4-2 PGDS-50-0-K Modes of Operation

The PGDS-50-0-K operates with H input (i.e 9-36Vdc) family of GAIA Converter DC/DC Converters. The PGDS-50-0-K features 4 modes of operations as follow:

- **Low line operation :**

Low line operation occurs when the input bus voltage drops down below the permanent input voltage range of the DC/DC converter i.e 9 Vdc.

The PGDS-50-0-K then operates in boost mode to provide an output voltage compatible with the DC/DC converter. The PGDS-50-0-K series can sustain low line operation down to 6V during 1 sec.

- **Power fail operation :**

An undervoltage lock-out stops operation for voltage below this low line operation threshold.

- **Normal operation :**

Normal operation occurs between the permanent input voltage of DC/DC converter; The module is then operating in steady transparency state.

- **Transient and spike operation :**

The PGDS-50-0-K clamps input transient up to 100V as long as 50ms.

PGDS-50-0-K Transfert Function

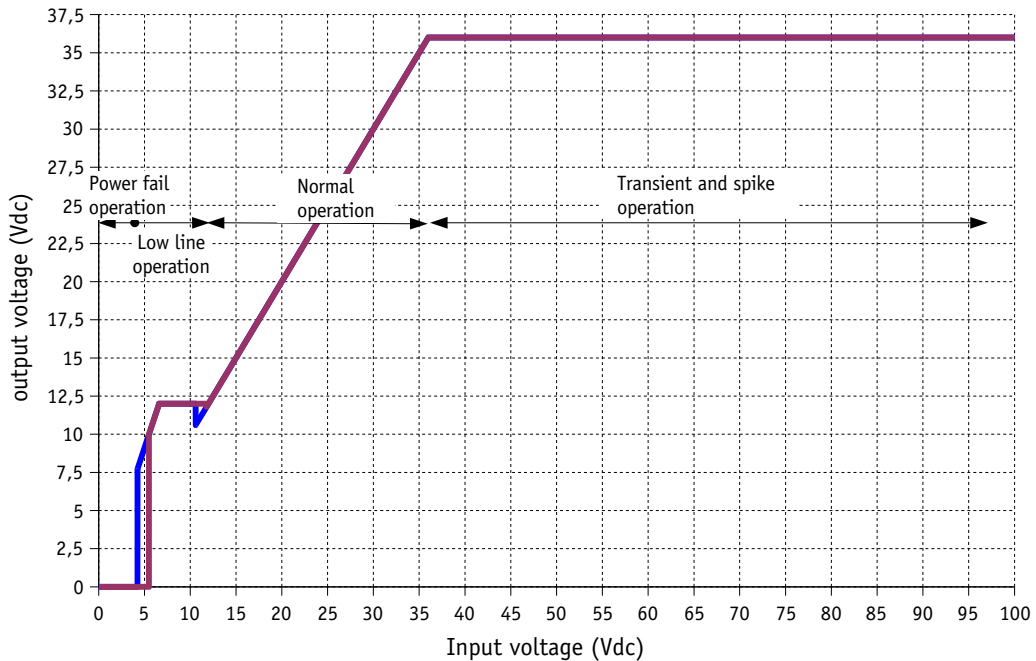

Parameter	Unit	Min.	Typ.	Max.	Notes, conditions
Power Fail Operation :					
Undervoltage Lockout On	Vdc	5,35	/	5,65	/
Undervoltage Lockout Off	Vdc	4,12	/	4,38	/
Low Line Operation :					
Voltage Low Line Operation On	Vdc	11,40	/	11,80	/
Voltage Low Line Operation Off	Vdc	11,70	/	12,00	/
Maximum output power 6V@1s	W	/	/	30	see page 6
Normal Operation :					
Maximum output power	W	/	/	50	see page 6
Transient & Surge Operation :					
Maximum output power at 100V/50ms	W	/	/	30	see page 6

5- Electrical Specifications

Data are valid at +25°C, unless otherwise specified.

Parameter	Conditions	Limit or typical	Units	PGDS-50-N-K	PGDS-50-O-K
Input					
Compatible module	J series of DC/DC module H series of DC/DC module	16-40Vdc 9-36Vdc		J series	H series
Under voltage lock-out (UVLO)	Turn-on voltage	Typical	VDC	12	6
	Turn-off voltage	Typical	VDC	9	5,65
Start up time	Ui min. to max. No load to full load	Maximum	ms	15	15
Permanent input voltage range (Ui) in normal operation	Full temperature range	Minimum	VDC	17	12
	Full load	Maximum	VDC	37	37
Compliance with standards voltage drop-out limit in low line operation	Full temperature range	Minimum	VDC/s	10V/30s	6V/1s
		MIL-STD-704A	10V/50ms	Compliant	Compliant
		AECMA EN2282	12V/30ms	Compliant	Compliant
		AIR2021E	12V/50ms	Compliant	Compliant
		DO160D cat A/B/Z	10V/15s	Compliant	Compliant
MIL-STD-1275A/B	6V/1s	Not compliant	Compliant		
Compliance with standards voltage transient limit	Full temperature range	Maximum	VDC/ms	80V/100ms	100V/50ms
		Maximum	VDC/s	48V/1s	48V/1s
		MIL-STD-704A	80V/75ms	Compliant	Compliant
		AECMA EN2282	60V/50ms	Compliant	Compliant
		AIR2021E	60V/100ms	Compliant	Compliant
DO160D cat A/Z	80V/100ms	Compliant	Compliant		
MIL-STD-1275A/B	100V/50ms	Not compliant	Compliant		
Compliance with standards voltage spike limit *with companion filter FGDS series	50 Ohms impedance 50 Ohms impedance 50 Ohms impedance 50 Ohms impedance 15 mJ energy content	MIL-STD-704A	600V/10µs	Compliant*	Compliant*
		AECMA EN2282	400V/100µs	Compliant*	Compliant*
		AIR2021E	600V/10µs	Compliant*	Compliant*
		DO160D cat A/Z	600V/10µs	Compliant*	Compliant*
		MIL-STD-1275A/B	250V/70µs	Not compliant	Compliant*
Current in inhibit mode		Maximum	mA	25	25
Output					
Output voltage range	Ui min. to max.	Minimum	VDC	16	9
	Full load	Maximum	VDC	40	36
Nominal voltage in normal operation		Nominal	VDC	Ui - 0,6	Ui - 0,6
Nominal voltage in low line operation	In low line Input voltage	Nominal	VDC	see page 6 figure 1	see page 6 figure 2
		Minimum	VDC		
Nominal voltage in transient protection mode	In transient Input voltage	Nominal	VDC	see page 6 figure 3	see page 4 figure 4
Efficiency	Ui = 28VDC Full load	Minimum	%	96	96
Output power range	Full temperature range	Minimum	W	see page 6 figure 5	see page 6 figure 6
	In low line operation	Maximum	W		
	In transient operation	Maximum	W		

5- Electrical Characteristics (continued)

Figure 1 : PGDS-50-N-K Brown-Out Response at 10Vdc

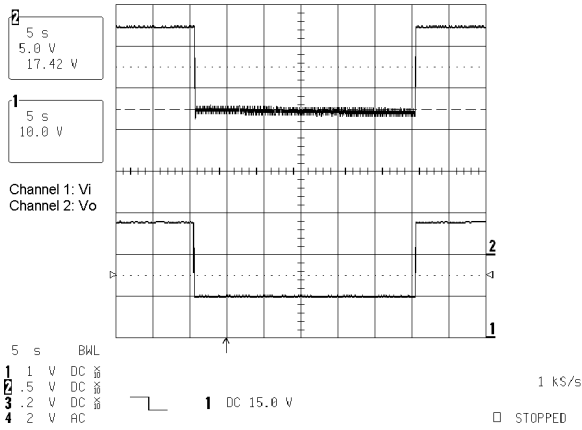

Figure 2 : PGDS-50-0-K Brown-Out Response at 6Vdc

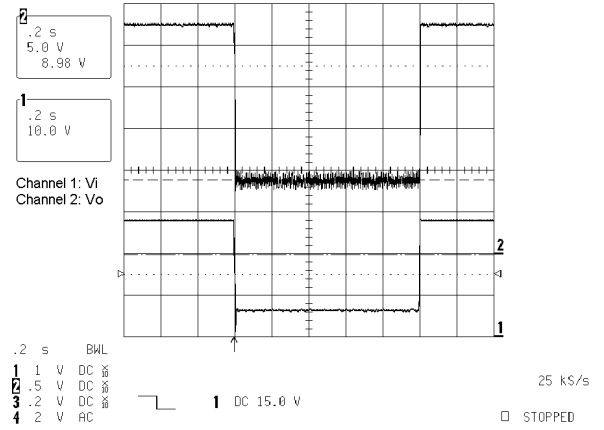

Figure 3 : PGDS-50-N-K Transient Response at 80Vdc

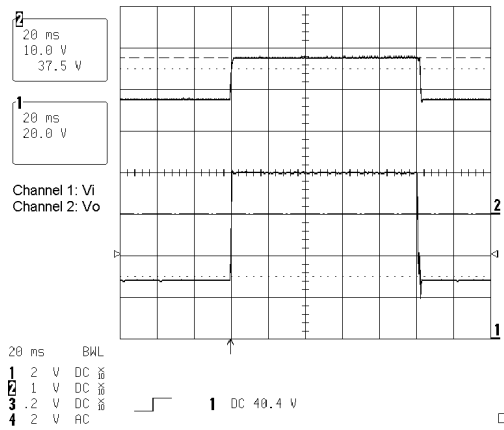

Figure 4 : PGDS-50-0-K Transient Response at 100Vdc

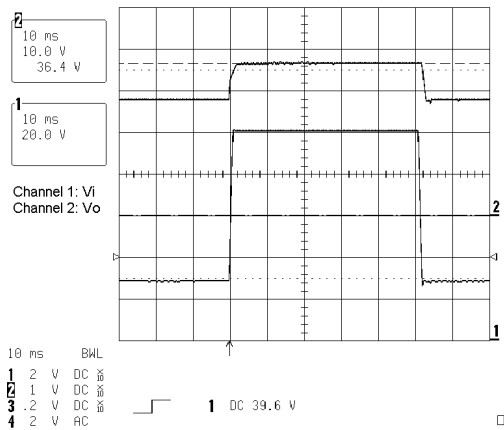

Figure 5 : PGDS-50-N-K Output Power versus Input Voltage

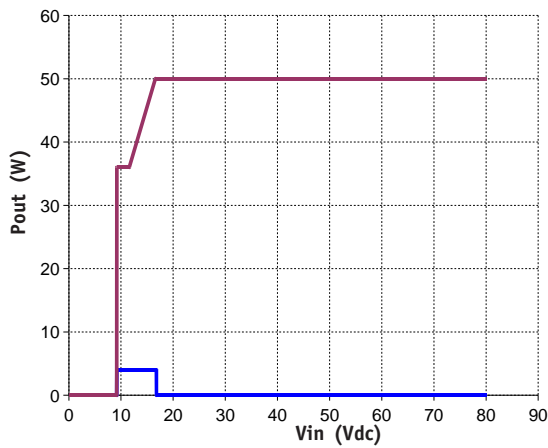
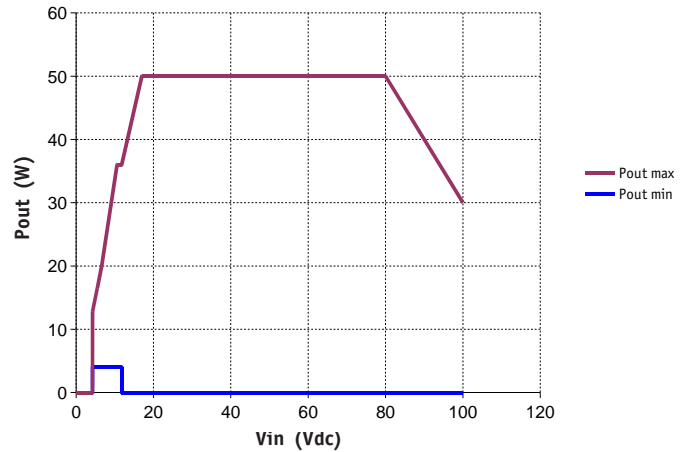

Figure 6 : PGDS-50-0-K Output Power versus Input Voltage



6- Switching Frequency

Parameter	Conditions	Limit or typical	Specifications
Switching frequency	Full temperature range Ui min. to max. No load to full load	Nominal, fixed in low line operation	500 KHz

7- Isolation

Parameter	Conditions	Limit or typical	Specifications
Electric strength test voltage	Input to output	Minimum	No isolation
	Input to case Output to case	Minimum	1 500 VDC / 1 min 1 500 VDC / 1 min
Isolation resistance	500 VDC	Minimum	100 MΩ

8- Protection Functions

Characteristics	Protection Device	Recovery	Limit or typical	Specifications
Input undervoltage lock-out (UVLO)	Turn-on, turn-off circuit with hysteresis	Automatic recovery	Typical	see section 5

9- Reliability Data

Characteristics	Conditions	Temperature	Specifications
Mean Time Between Failure (MTBF) According to MIL-HDBK-217F	Ground fixed (Gf)	Case at 40°C Case at 85°C	1 700 000 Hrs 710 000 Hrs
	Airborne, Inhabited, Cargo (AIC)	Case at 40°C Case at 85°C	850 000 Hrs 360 000 Hrs
Mean Time Between Failure (MTBF) According to IEC-62380-TR	Civilian avionics, calculators	Ambient at 55°C 100% time on	Consult factory

10- Thermal Characteristics

Characteristics	Conditions	Limit or typical	Performances
Operating ambient temperature range at full load	Ambient temperature *	Minimum Maximum	- 40°C + 85°C
Operating case temperature range at full load	Case temperature	Minimum Maximum	- 40°C +105°C
Storage temperature range	Non functioning	Minimum Maximum	- 55°C + 125°C
Thermal resistance	Rth case to ambient in free air natural convection	Typical	12°C /W

Note * : The upper temperature range depends on configuration, the user must assure a max. case temperature of + 105°C.

The PGDS-50 series operating **case** temperature at full load must not exceed 105°C. The maximum **ambient** temperature admissible for the DC/DC converter corresponding to the maximum operating case temperature of 105°C depends on the ambient airflow, the mounting/orientation, the cooling features and the power dissipated.

To calculate a maximum admissible ambient temperature the following method can be used. Knowing the maximum case temperature Tcase = 105°C of the module, the power used Pout and the efficiency η :

- determine the power dissipated by the module P_{diss} that should be evacuated :

$$P_{diss} = P_{out}(1/\eta - 1)$$

- determine the maximum ambient temperature :

$$T_a = 105^\circ\text{C} - R_{th} \times P_{diss}$$

where **Rth** is the thermal resistance from the case to ambient.

The previous thermal calculation shows two areas of operation :

- a normal operation area in a free natural ambient convection (grey area in this following graph),
- an area with cooling features (air flow or heatsink) ensuring a maximum case temperature below the maximum operating case temperature of 105°C at full load (white area in the following graph).

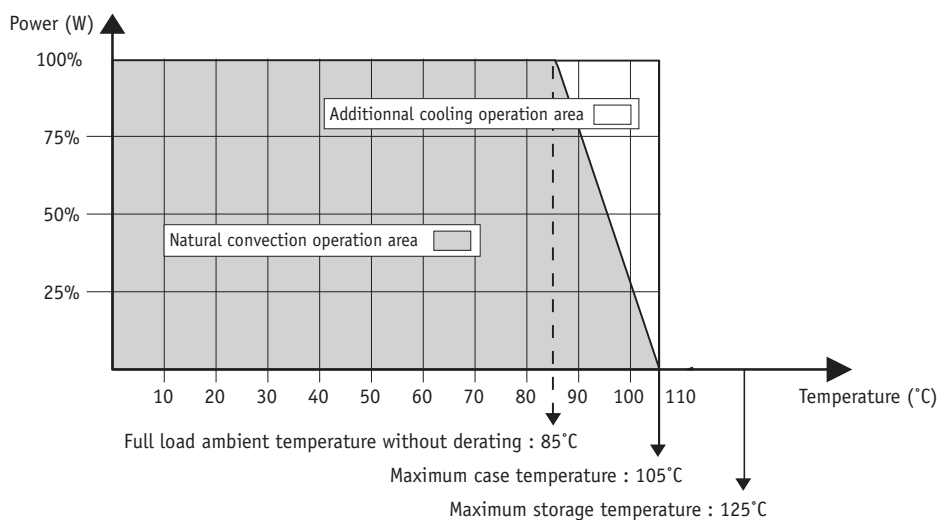

11- Environmental Qualifications

The modules have been subjected to the following environmental qualifications.

Characteristics	Conditions	Severity	Test procedure
Climatic Qualifications			
Life at high temperature	Duration Temperature / status of unit	Test D : 1 000 Hrs @ 105°C case, unit operating @ 125°C ambient, unit not operating	MIL-STD-202G Method 108A
Altitude	Altitude level C Duration Climb up Stabilization Status of unit	40 000 ft@-55°C 30 min. 1 000 ft/min to 70 000 ft@-55°C, 30 min. unit operating	MIL-STD-810E Method 500.3
Humidity cyclic	Number of cycle Cycle duration Relative humidity variation Temperature variation Status of unit	10 Cycle I : 24 Hrs 60 % to 88 % 31°C to 41°C unit not operating	MIL-STD-810E Method 507.3
Humidity steady	Damp heat Temperature Duration Status of unit	93 % relative humidity 40°C 56 days unit not operating	MIL-STD-202G Method 103B
Salt atmosphere	Temperature Concentration NaCl Duration Status of unit	35°C 5 % 48 Hrs unit not operating	MIL-STD-810E Method 509.3
Temperature cycling	Number of cycles Temperature change Transfer time Steady state time Status of unit	200 -40°C / +85°C 40 min. 20 min. unit operating	MIL-STD-202A Method 102A
Temperature shock	Number of shocks Temperature change Transfer time Steady state time Status of unit	100 -55°C / +105°C 10 sec. 20 min. unit not operating	MIL-STD-202G Method 107G
Mechanical Qualifications			
Vibration (Sinusoidal)	Number of cycles Frequency / amplitude Frequency / acceleration Duration Status of unit	10 cycles in each axis 10 to 60 Hz / 0.7 mm 60 to 2 000 Hz / 10 g 2h 30 min. per axis unit not operating	MIL-STD-810D Method 514.3
Shock (Half sinus)	Number of shocks Peak acceleration Duration Shock form Status of unit	3 shocks in each axis 100 g 6 ms 1/2 sinusoidal unit not operating	MIL-STD-810D Method 516.3
Bump (Half sinus)	Number of bumps Peak acceleration Duration Status of unit	2 000 Bumps in each axis 40 g 6 ms unit not operating	MIL-STD-810D Method 516.3

12- Application Notes

12-1 Reverse Polarity Compatibility

The PGDS-50 is compatible with an external reverse input polarity protection connected directly on Vin (pin 1). GAIA Converter recommends a diode with a minimum current rating of 7 A and a voltage breakdown rating greater than 100V.

12-2 On/Off Function

The control pin 3 (On/Off) can be used for applications requiring On/Off operations. By using an open collector command with a transistor Q referenced to the terminal Gi :

- A logic pulled low (<math><0.2V@1mA</math>, referenced to Gi) on pin 3 disables the converter.
- No connection or high impedance on pin 3 enables the converter.

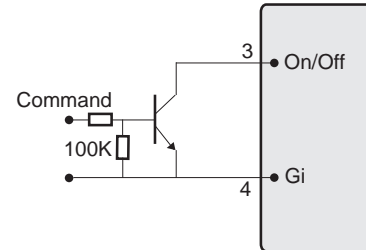

12-3 EMI Compatibility with MIL-STD-461C and MIL-STD-461D/E

The PGDS-50 series includes a π EMI filter to attenuate ripple and noise. To meet MIL-STD-461C and MIL-STD-461D/E requirements, GAIA Converter recommends the use of an external filter (see section 12-5 Typical Schematics and EMI filters design notes for details).

12-4 VIMES Signal

The VIMES signal is used to sense the input bus voltage and depending on the achieved level, to drive the mode of operation of the PGDS-50.

Due to possible oscillation caused by surge or fast transients on the bus line, it is recommended to implement an R*C* filter on this signal as described in the following schematics. The connection of VIMES through the resistance R could be done before or after the EMI input filter (see section 12-5 Typical Schematics).

If no RC filter is used, connect pin VIMES to pin Vi.

12-5 Typical Schematics

The PGDS-50 series is suitable to be used with several DC/DC GAIA converter modules in various configurations as follow :

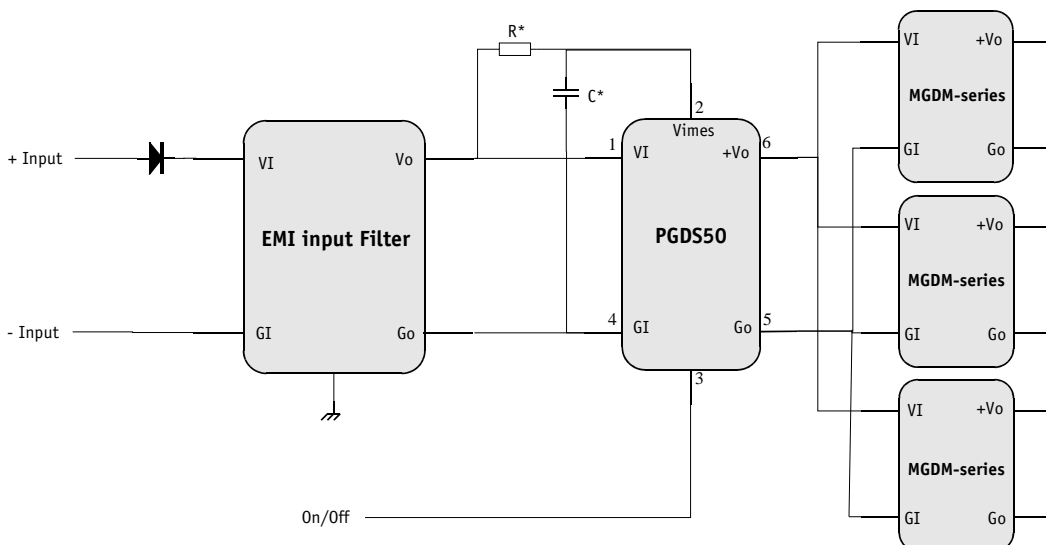

Note * : Typical value of resistor R* is : 470 Ohm, typical value of capacitor C* is : 1 μ F
Please consult EMI filters datasheet for further details on EMI.

13- Dimensions

Dimension are given in mm (inches). Tolerance : +/- 0,2 mm (+/- 0.01 ") unless otherwise indicated.
 Weight : 20 grams (0.7 Ozs) max.

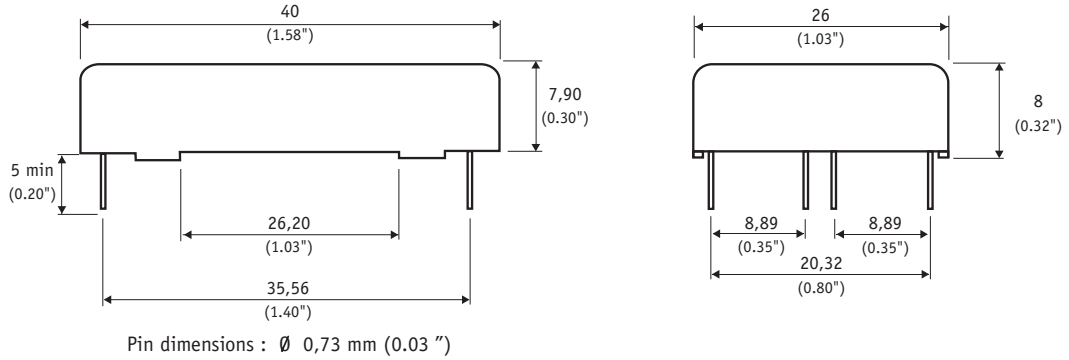

14- Materials

Case : Metallic black anodized coating.
 Pins : Plated with pure matte tin over nickel underplate.

15- Product Marking

Upper face : Company logo.
 Side face : Module reference : PGDS-50-»X»-»Y».
 Date code : year and week of manufacturing, suffix, /option.

16- Connections

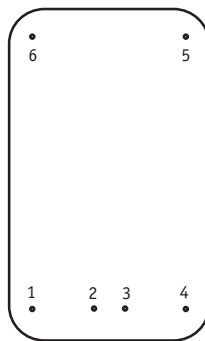

Bottom view

Pin	PGDS-50
1	+ Input (Vi)
2	Input measure (VIMES)
3	On / Off
4	- Input (Gi)
5	Common (Go)
6	Output (Vo)



Represented by :

Information given in this datasheet is believed to be accurate and reliable. However, no responsibility is assumed for the consequence of its use nor for any infringement of patents or other rights of third parties which may result from its use. These products are sold only according to GAIA Converter general conditions of sale, unless otherwise confirmed by writing. Specifications subject to change without notice.